

RICON® 120/40



Assemblage poteau - traverse
 avec Avis Technique (EU + DE)
post and latch connection -
 with construction supervisory approval (EU + DE)

<p>RICON 120/40</p>	<p>Vis RICON SK / RICON SK Scr 8x80</p>	<p>Vis tête fraisée, empreunte 6 pans / Countersunk socket screw M8x25, M8x20</p>
	<p>Vis RICON SK / RICON SK Scr 8x50</p>	<p>Entretoise/ connecting nut M8x36, 48, 53, 58, 78</p>
	<p>Vis RICON SK / RICON SK Scr 5x80</p>	<p>Insert / insert screw M8x18</p>
	<p>Vis RICON SK / RICON SK Scr 5x50</p>	
	<p>Goupille de verrouillage / stirrup</p>	

Assemblage simple et doublé
 Single and double connection

Assemblage poteau - traverse
 Latch and post connection

Détails du fraisage traverse /
 Milled edge latch

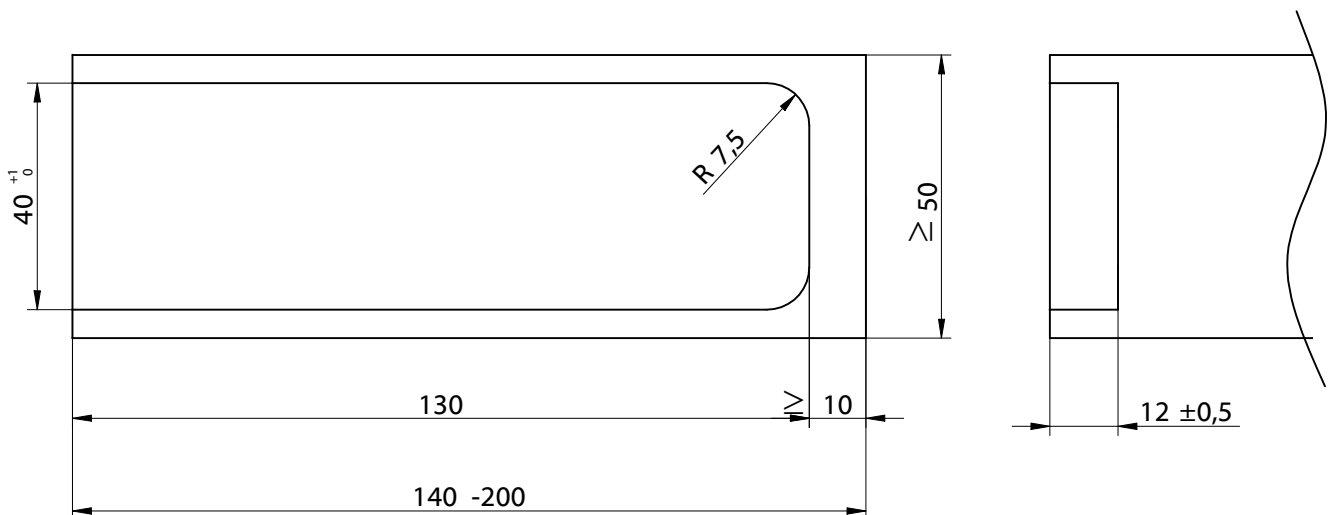

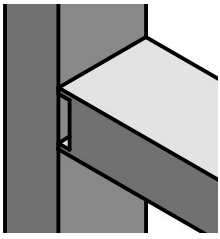

Notice de montage/Construction Manual

RICON® 120/40 EA

Assemblage simple
Single connection

Assemblage poteau - traverse
Latch and post connection

Réf. K363

Détail du perçage sur la traverse/
Drilling template for latch

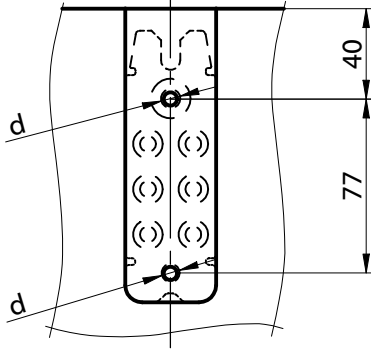

d...pré-percer Ø 5mm, prof. 30mm
d...Ø 5mm, 30mm deep predrilling

Détail du perçage sur le poteau/
Drilling template for post

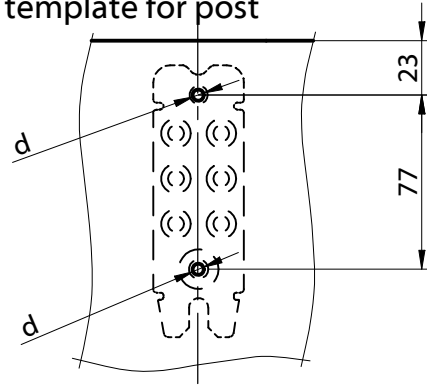

d...pré-percer Ø 5mm, prof. 30mm
d...Ø 5mm, 30mm deep predrilling

Détail du vissage sur la traverse /
screw template for latch

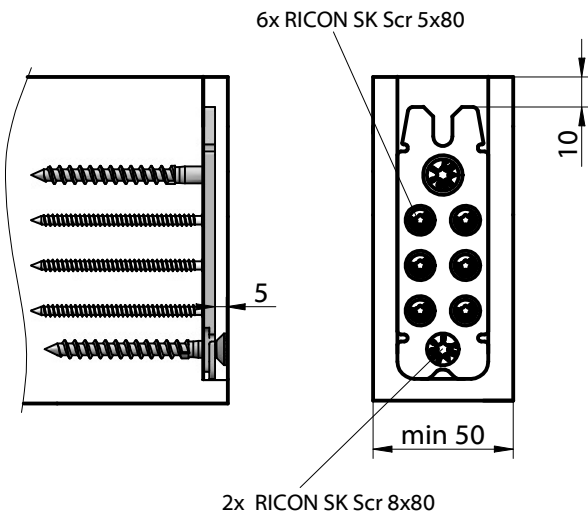

Détail du vissage sur le poteau/
Screw template for post

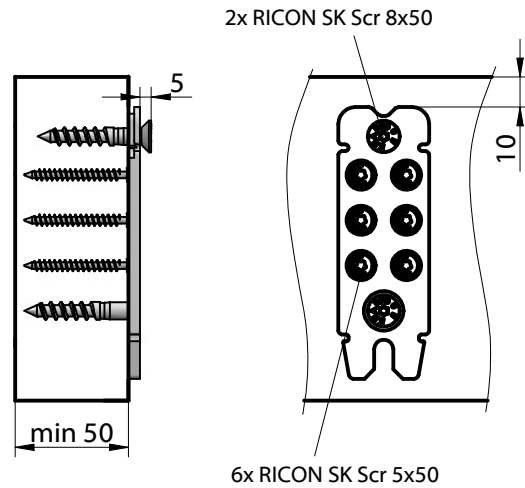

Régler la vis d'accroche /
Screw position adjustment

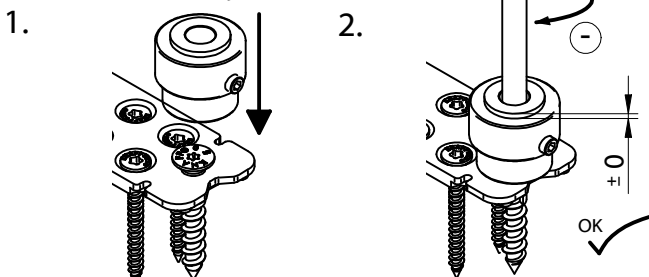

Mettre la goupille en place/
Assemble stirrup

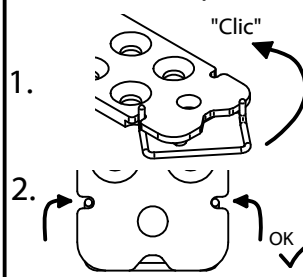

Déverrouiller la goupille /
Remove stirrup

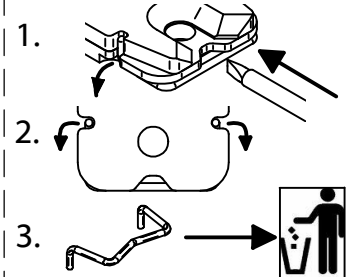

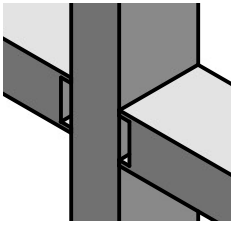

Notice de montage/Construction Manual

RICON® 120/40 DA

Réf. K163/48;
K163/58; K163/78

Assemblage doublé
Double connection

Assemblage poteau - traverse
Latch and post connection

Détail du perçage sur la traverse/
Drilling template for latch

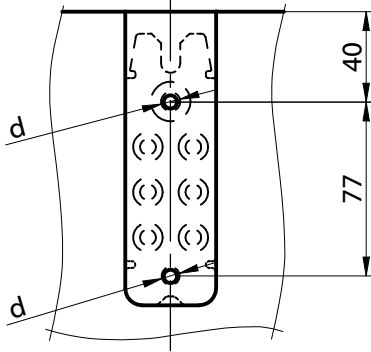

d...pré-percer Ø 5mm, prof. 30mm
d...Ø 5mm, 30mm deep predrilling

Détail du perçage sur le poteau/
Drilling template for post

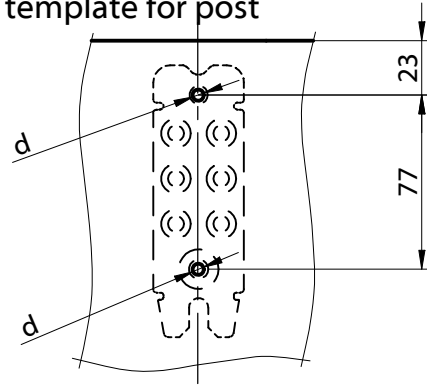

d...pré-percer en traversant Ø 10mm,
d...Ø 10mm, throughhole

Détail du vissage sur la traverse /
screw template for latch

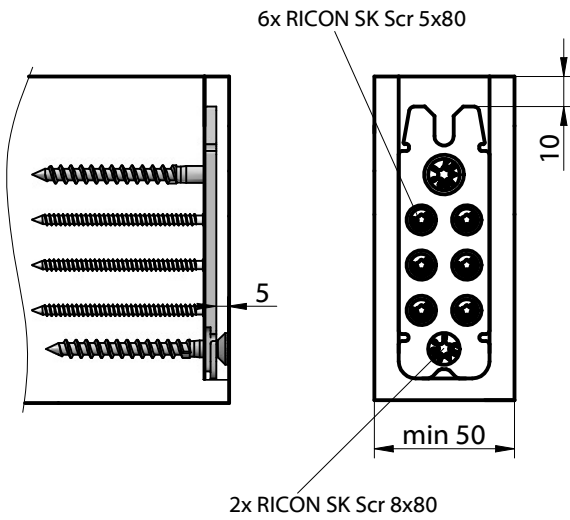

2x RICON SK Scr 8x80

Détail du vissage sur le poteau/
Screw template for post

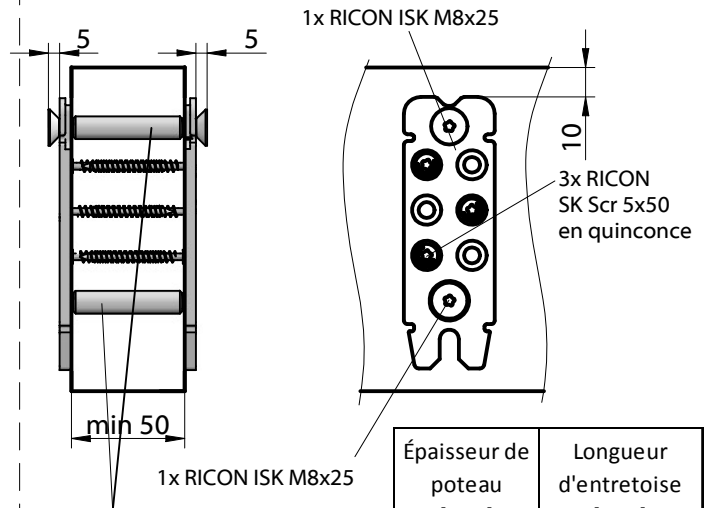

2 x Entretoises/
connecting nut
M8 x 36, 48, 53, 58
ou 78

Épaisseur de poteau [mm]	Longueur d'entretoise [mm]
50	48
56	53
60	58
80	78

Régler la vis d'accroche /
Screw position adjustment

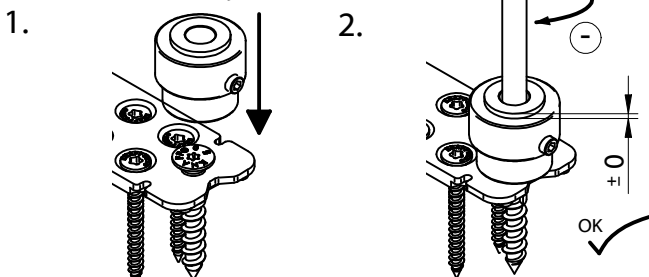

Mettre la goupille en place/
Assemble stirrup

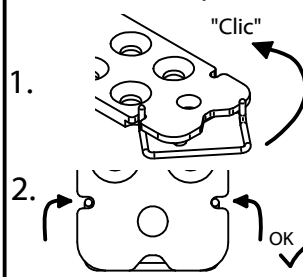

Déverrouiller la goupille /
Remove stirrup

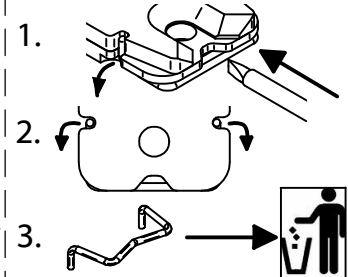

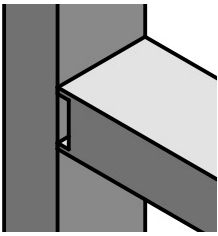

Notice de Montage/Construction Manual

RICON® 120/40 EAR

Réf. K263

Assemblage simple avec insert

Single connection with insert screw

Assemblage poteau - traverse

Latch and post connection

Détail du perçage sur la traverse /
Drilling template for latch

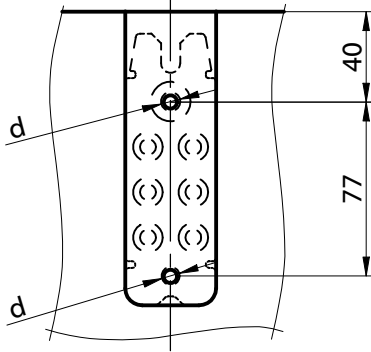

d...pré-perçer Ø 5mm, prof. 30mm
d...Ø 5mm, 30mm deep predrilling

Détail du perçage sur le poteau /
Drilling template for post

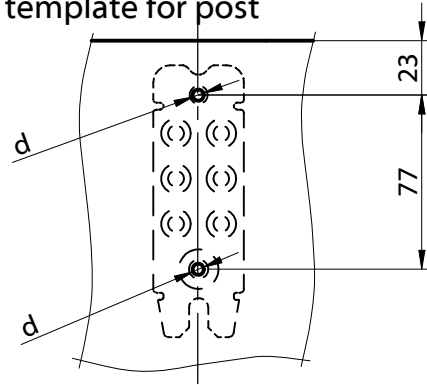

d...pré-perçer Ø 12mm, prof. 20mm
d...Ø 12mm, 20mm deep predrilling

Détail du vissage sur la traverse /
screw template for latch

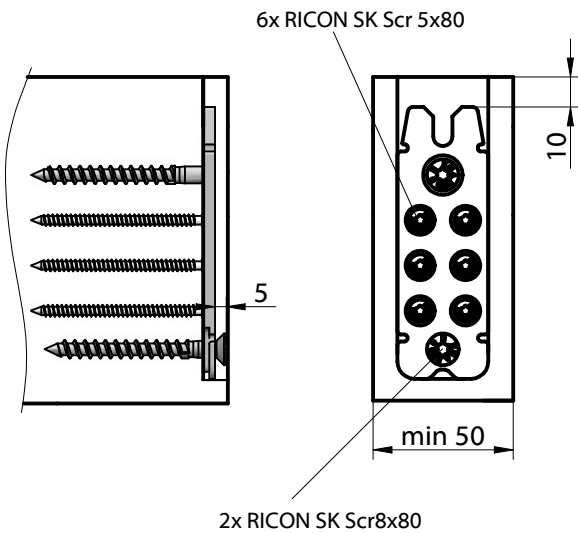

Détail du vissage sur le poteau /
Screw template for post

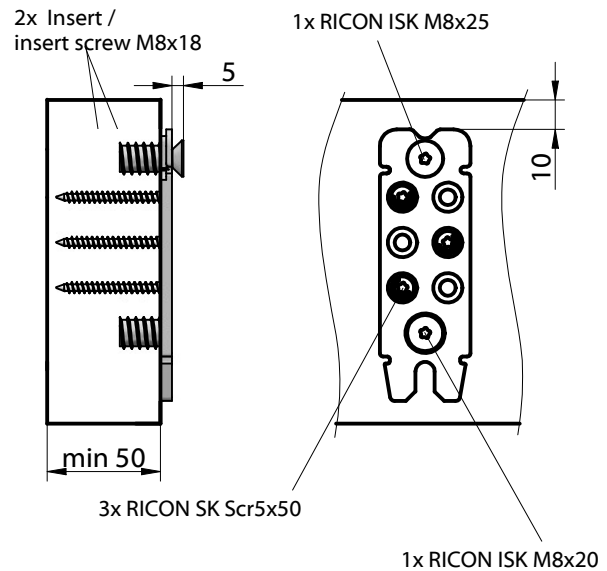

Régler la vis d'accroche /
Screw position adjustment

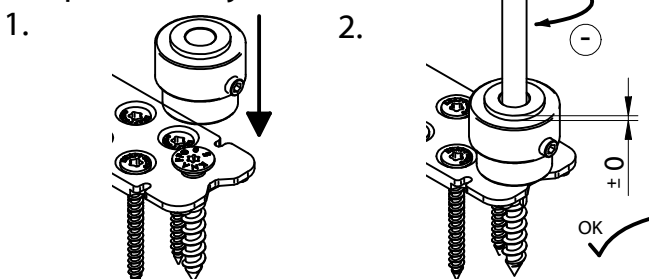

Mettre la goupille en place /
Assemble stirrup

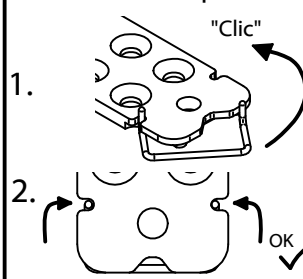

Déverrouiller la goupille /
Remove stirrup

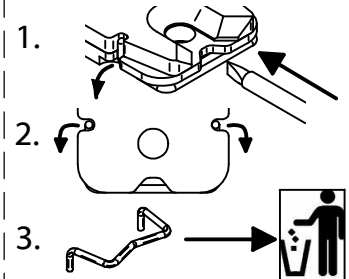

Notice de montage/Construction Manual

RICON® 120/40

Assemblage de poutre secondaire sur principale

- avec Avis Technique (EU + DE)

Main girder- joist connection

- with construction supervisory approval (EU + DE)



RICON 120/40

Vis RICON SK /
RICON SK Scr 8x80

Vis RICON SK /
RICON SK Scr 8x50

Vis RICON SK /
RICON SK Scr 5x80

Vis RICON SK /
RICON SK Scr 5x50

Goupille de verrouillage /
stirrup

Vis tête fraisée, emprunte 6 pans /
Countersunk socket screw
M8x25, M8x20

Entretoise/ connecting nut
M8x36, 48, 53, 58, 78

Insert / insert screw M8x18

Assemblage simple et doublé
Single and double connection

Poutre secondaire sur principale
Main girder - joist connection

Détails du fraisage poutre principale/ Milled edge main girder

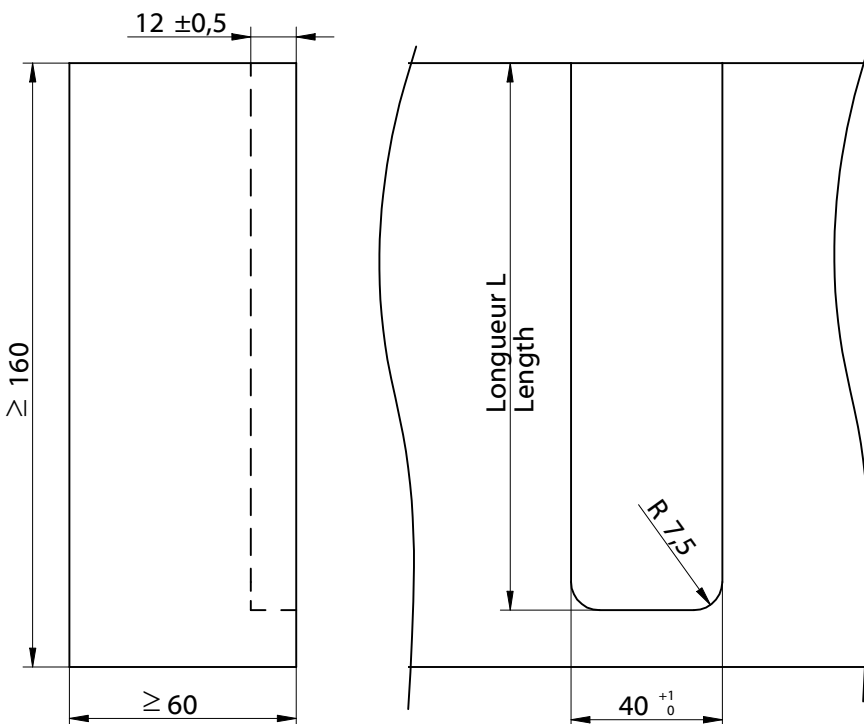

Long. de fraisage L sur pièce principale, en relation avec Ht. pièce secondaire HN /
Rebate length for main girder in reference of the height HN of the joist:

Hauteur / Height HN [mm]	Long. / Length L [mm]
160	140
180	160
200	170
220	180

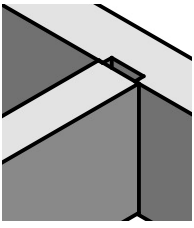

Notice de montage/Construction Manual RICON® 120/40 EA

Assemblage simple
Single connection

Poutre secondaire sur principale
Main girder - joist connection

Réf. K363

Détail du perçage sur la poutre principale / Drilling template for main girder

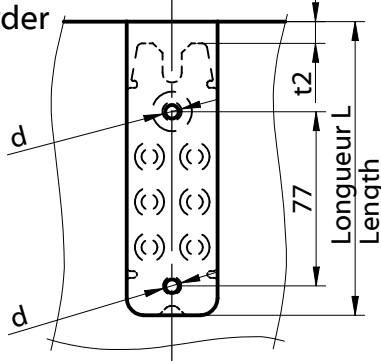

d...pré-percer Ø 5mm, prof. 30mm
d...Ø 5mm, 30mm deep predrilling

Détail du perçage sur la poutre secondaire / Drilling template for joist

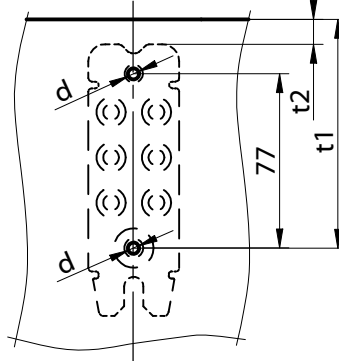

d...pré-percer Ø 5mm, prof. 30mm
d...Ø 5mm, 30mm deep predrilling

Distance de perçage t1 et t2, en relation avec la hauteur de la pièce secondaire HN / Bore measure t1 and distance t2 for joist in reference to the height HN of the joist

Hauteur / Height HN [mm]	Distance t1 [mm]	Distance t2 [mm]
160	110	20
180	130	40
200	140	50
220	150	60

Détail du vissage sur la poutre principale / Screw template for main girder

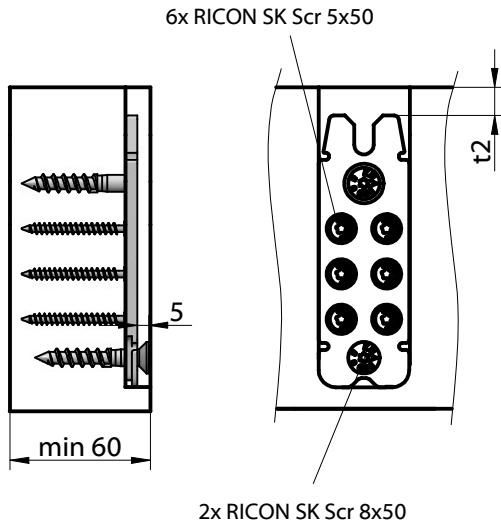

Détail du vissage sur la poutre secondaire / Screw template for joist

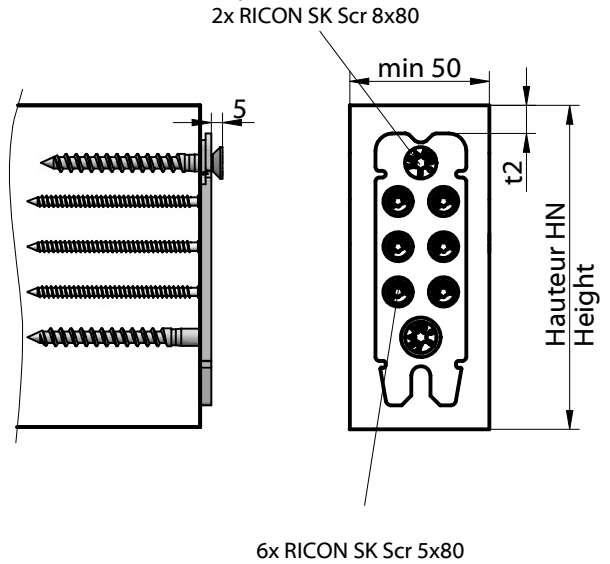

Régler la vis d'accroche / Screw position adjustment

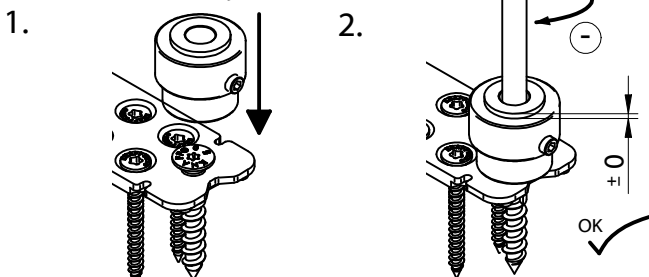

Mettre la goupille en place / Assemble stirrup

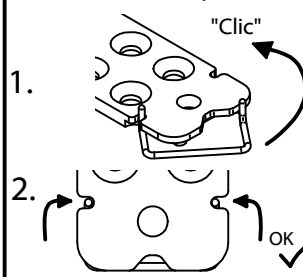

Déverrouiller la goupille / Remove stirrup

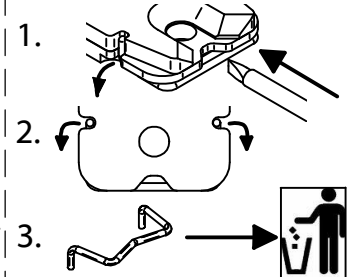

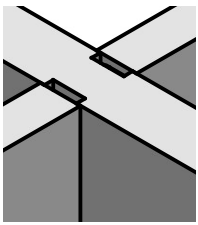

Notice de Montage/Construction Manual RICON® 120/40 DA

Réf. K163/48;
K163/58; K163/78

Assemblage doublé
Double connection

Poutre secondaire sur principale
Main girder - joist connection

Détail du perçage sur la poutre principale / Drilling template for main girder

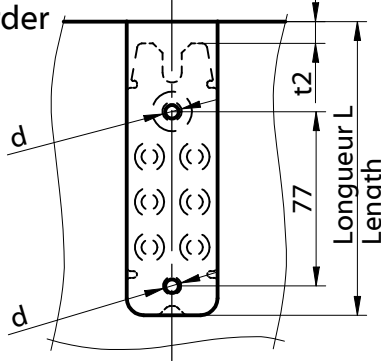

d...pré-percer en traversant Ø 10mm,
d...Ø 10mm, throughhole

Détail du perçage sur la poutre secondaire / Drilling template for joist

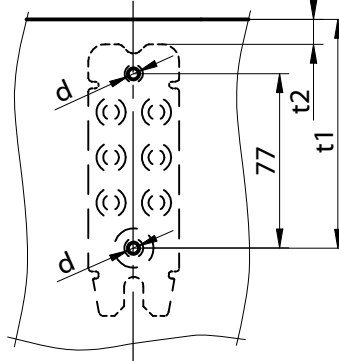

d...pré-percer Ø 5mm, prof. 30mm
d...Ø 5mm, 30mm deep predrilling

Distance de perçage t1 et t2, en relation avec la hauteur de la pièce secondaire HN / Bore measure t1 and distance t2 for joist in reference to the height HN of the joist

Hauteur / Height HN [mm]	Distance t1 [mm]	Distance t2 [mm]
160	110	20
180	130	40
200	140	50
220	150	60

Détail du vissage sur la poutre principale / Screw template for main girder

2x entretoises / connecting nut M8 x 36, 48, 53, 58 ou 78

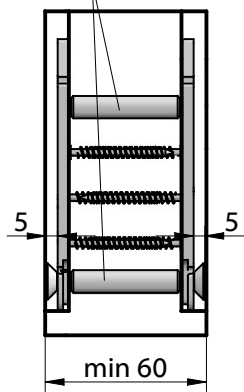

3x RICON SK Scr 5x50 en quinconce

1x RICON ISK M8x25

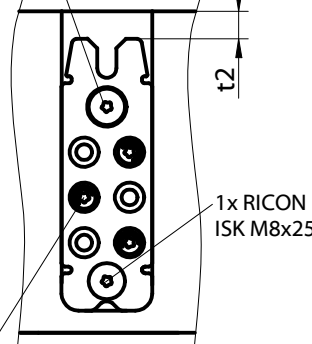

1x RICON ISK M8x25

Ép. de pièce principale [mm]	Longueur d'entretoise [mm]
60	36
80	53

Détail du vissage sur la poutre secondaire / Screw template for joist

2x RICON SK Scr 8x80

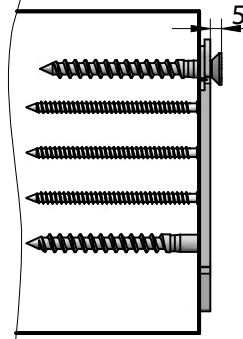

6x RICON SK Scr 5x80

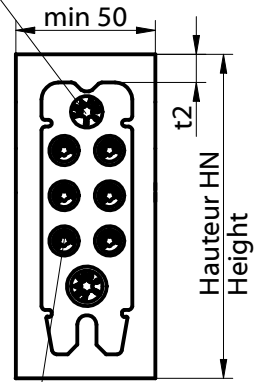

Régler la vis d'accroche / Screw position adjustment

1.

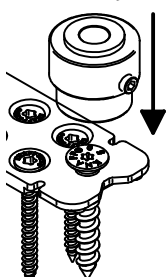

2.

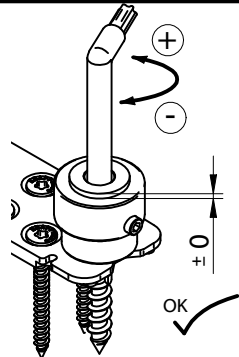

Mettre la goupille en place / Assemble stirrup

1.

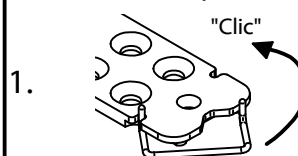

2.



Déverrouiller la goupille / Remove stirrup

1.

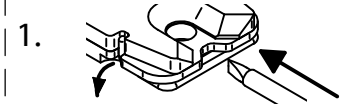

2.

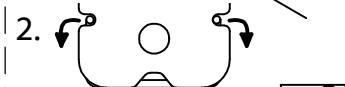

3.

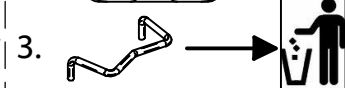

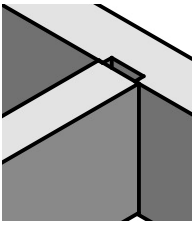

Notice de Montage/Construction Manual RICON® 120/40 EAR

Assemblage simple avec insert Poutre secondaire sur principale
Single connection with insert screw Main girder - joist connection

Réf. K263

Détail du perçage sur la poutre principale / Drilling template for main girder

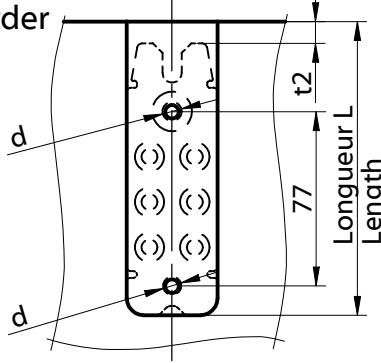

d...pré-percer Ø 12mm, prof. 20 mm
d...Ø 12mm, 20 mm deep predrilling

Détail du perçage sur la poutre secondaire / Drilling template for joist

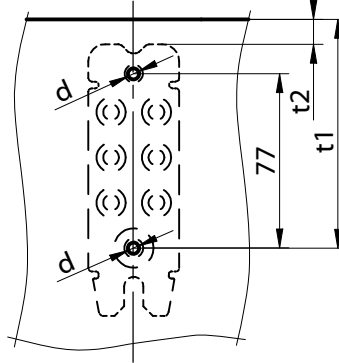

d...pré-percer Ø 5mm, prof. 30mm
d...Ø 5mm, 30mm deep predrilling

Distance de perçage t1 et t2, en relation avec la hauteur de la pièce secondaire HN / Bore measure t1 and distance t2 for joist in reference to the height HN of the joist

Hauteur / Height HN [mm]	Distance t1 [mm]	Distance t2 [mm]
160	110	20
180	130	40
200	140	50
220	150	60

Détail du vissage sur la poutre principale / Screw template for main girder

2x Insert / insert screw M8x18

1x RICON ISK M8x20

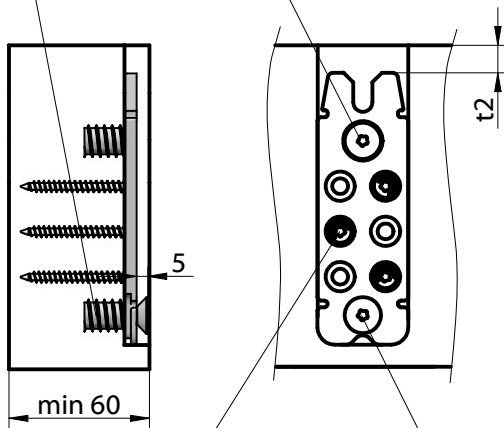

3x RICON SK Scr 5x50 en quinconce

1x RICON ISK M8x25

Détail du vissage sur la poutre secondaire / Screw template for joist

2x RICON SK Scr 8x80

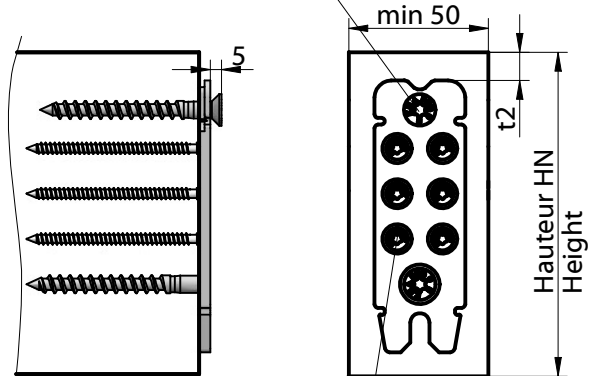

6x RICON SK Scr 5x80

Régler la vis d'accroche / Screw position adjustment

1. 2.

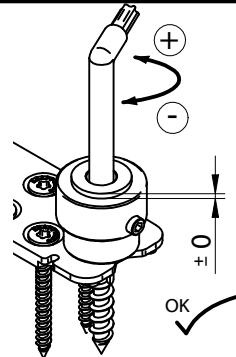
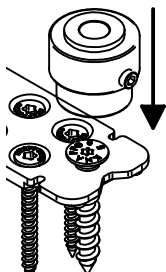

Mettre la goupille en place / Assemble stirrup

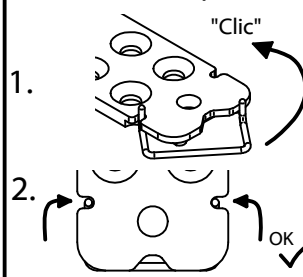

Déverrouiller la goupille / Remove stirrup

