

**Montageanleitung
DORMA RSP 80
Schiebetür Glas an Wand**

**Mounting instruction
DORMA RSP 80
Sliding door glass to wall**

Wichtige Informationen:
Important information:

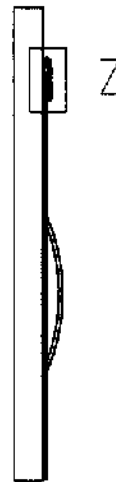
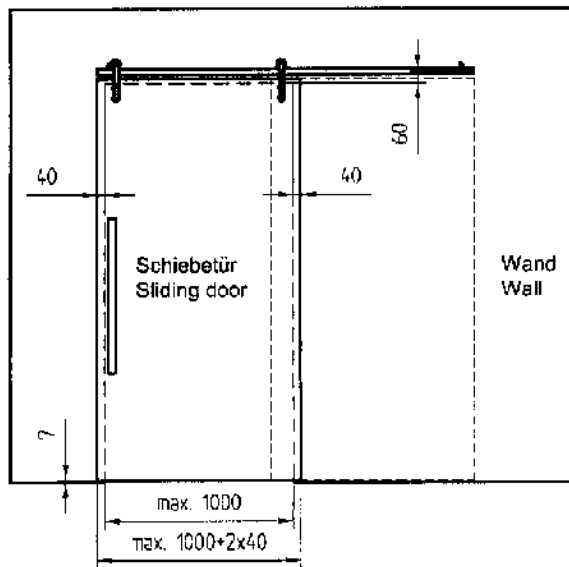

Detail Z

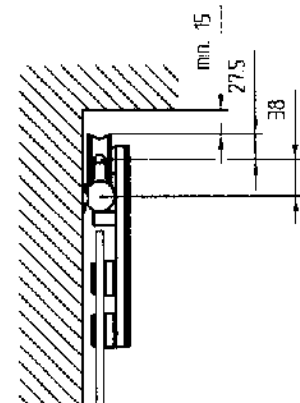

Vor der Montage Glasflächen
mit handelsüblichem Glasreiniger
im Bereich der Klemmflächen reinigen.

All glass clamping areas are to
be cleaned with standard glass
cleaning products prior to installation.

① = Bauteil/Baugruppe
Component

1.; 1.1 ; ... = Montagefolge
Mounting sequence



keine Verdünnung verwenden
Do not use thinner

Glasbearbeitung:
Glass preparation:

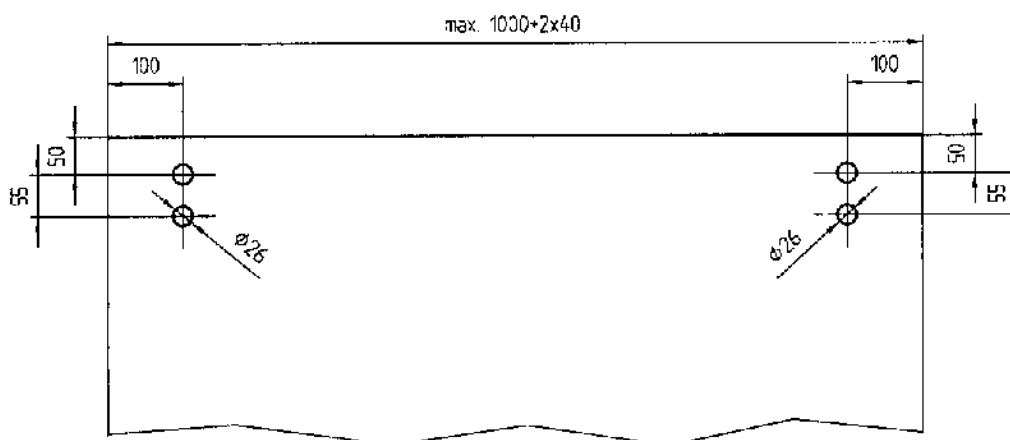

Montagewerkzeug:
Mounting tool:

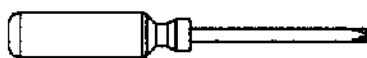
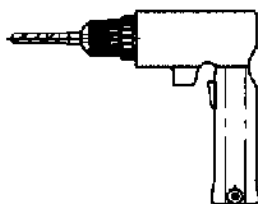

- 2 mm
- 3 mm
- 4 mm
- 5 mm

Lieferumfang:
Scope of delivery:

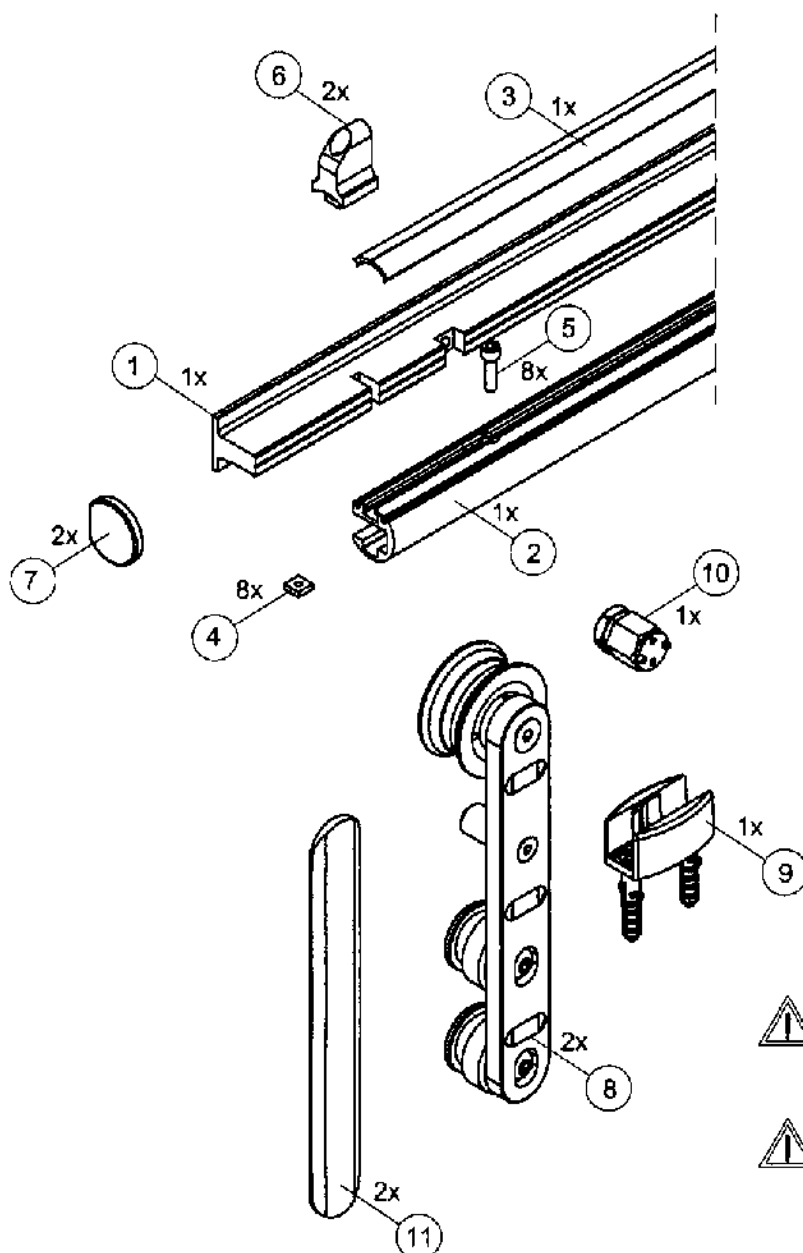

Schrauben und Dübel zur
Wandbefestigung sind nicht
im Lieferumfang enthalten!



Screws and wall plugs for wall
connection are not included in
delivery!

Lieferumfang:
Scope of delivery:

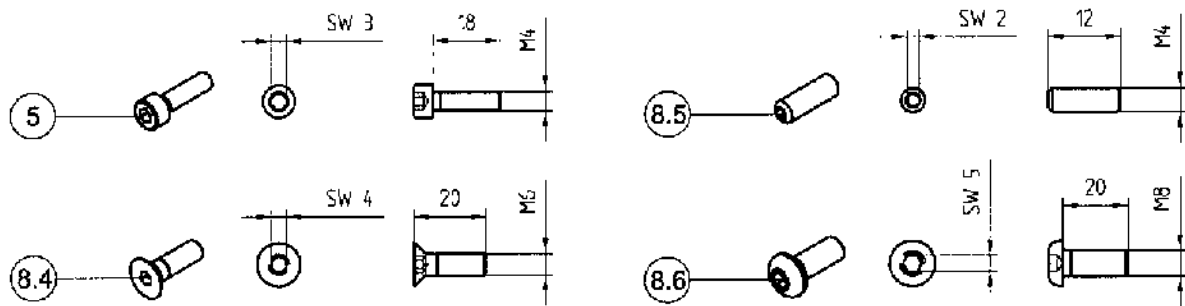

1. T-Profil an Wand schrauben:
1. Mounting of T-profile onto wall:

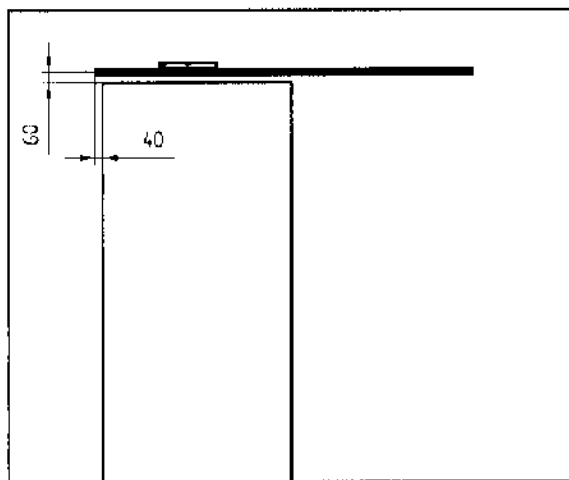

Schrauben und Dübel zur Wandbefestigung sind nicht im Lieferumfang enthalten!



Screws and plugs for wall connection are not included in delivery!

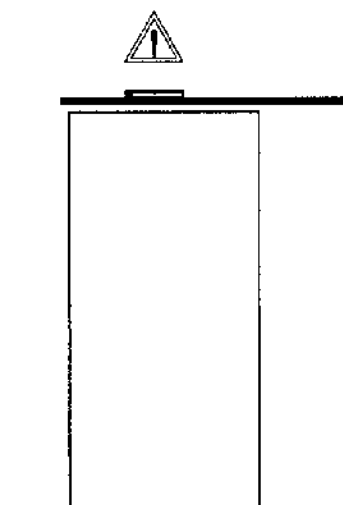
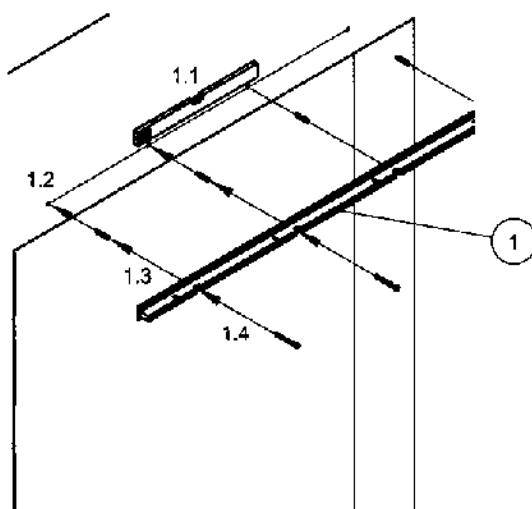

**2. Vorbereitung des Lauschienenprofils:
2. Preparing of the track rail profil:**

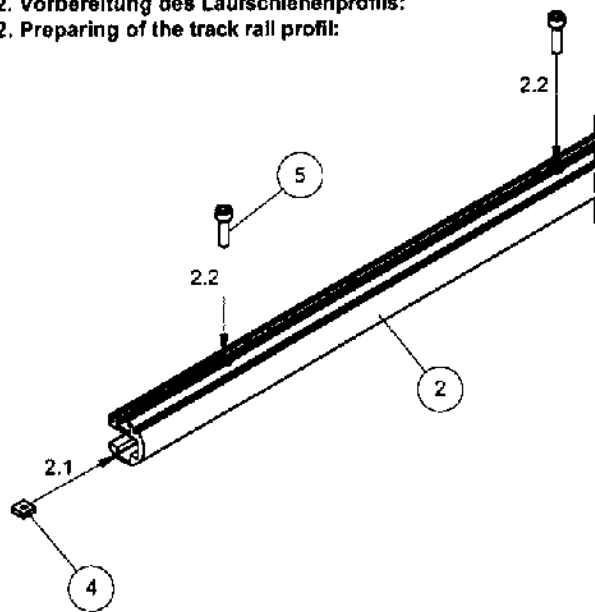

2.2 Schrauben ein Gewindegang in Nutsteine schrauben!
2.2 Tighten screws one convolution in slot nuts!

**3. Laufschiene auf T-Profil verschrauben:
3. Mounting of track profile on T-profile:**

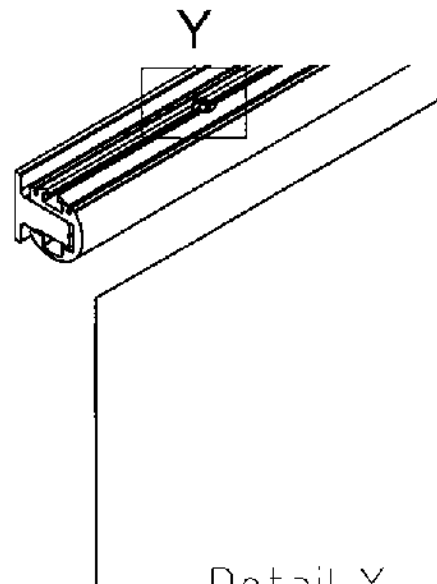
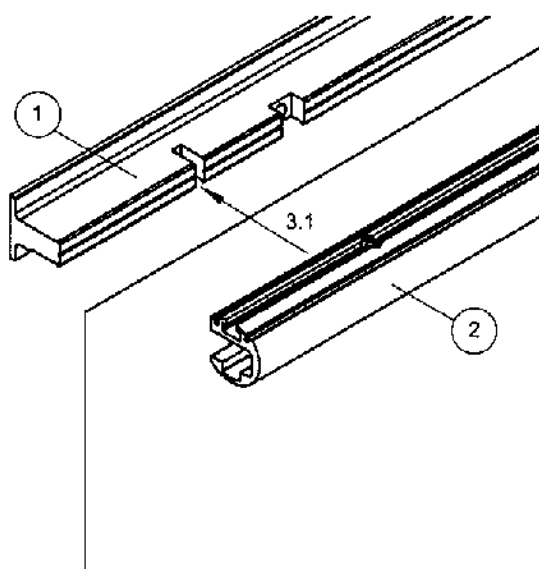

Detail Y

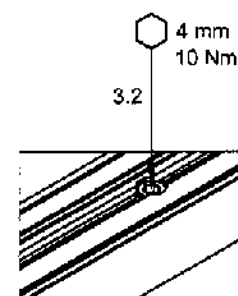
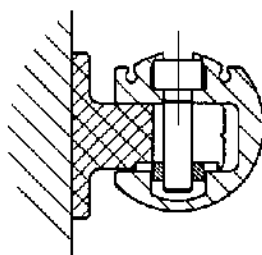

4. Rolprofil auf Laufschiene klippen:
4. Roll-profile connect to track rail:

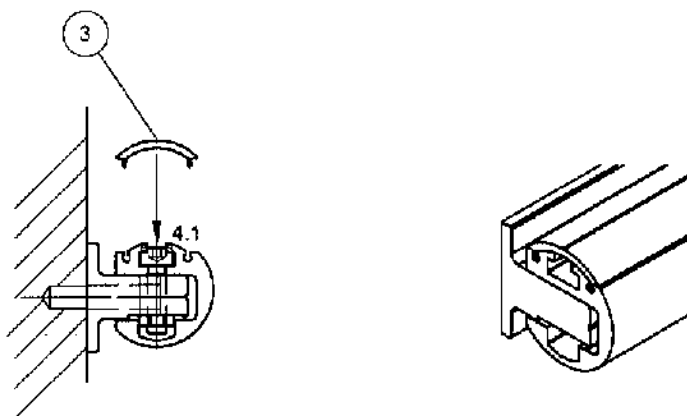

5. Vorbereitung Rollenwagen:
5. Preparing the track rail:

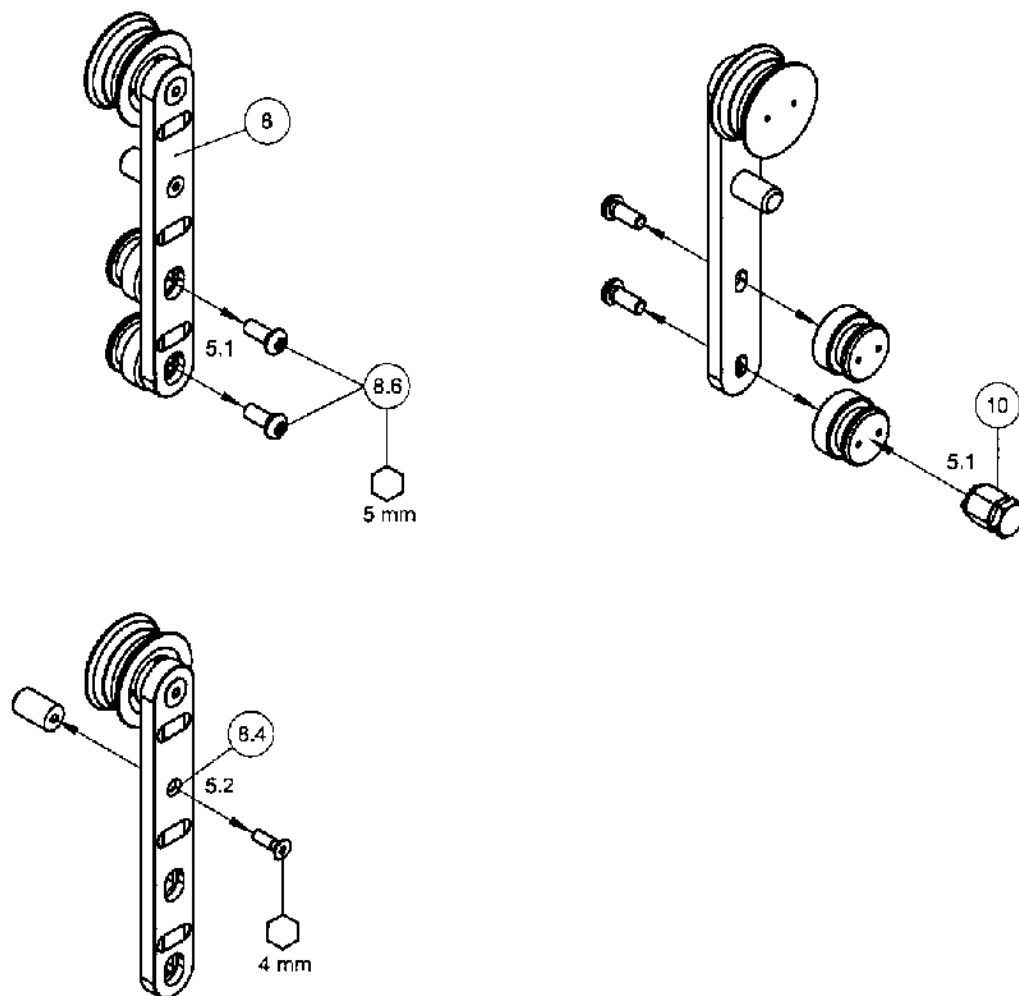

6. Montage Rollenwagen an Glas:
6. Mounting roller on glass:

6.3 Aufstecken und leicht anschrauben
 6.3 Attach and tighten easily

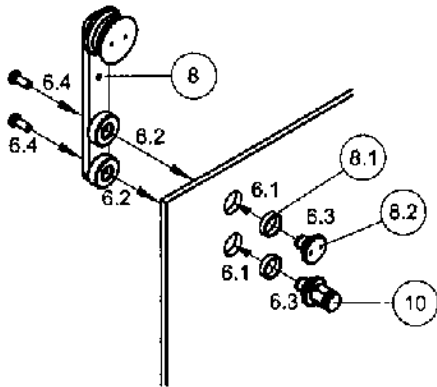

7. Bodenführung montieren:
7. Mounting of the floor guide:

7.1 Schiebetür einhängen und Bodenführung 9 markieren
 7.1 Fit sliding door and mark the floor guide 9

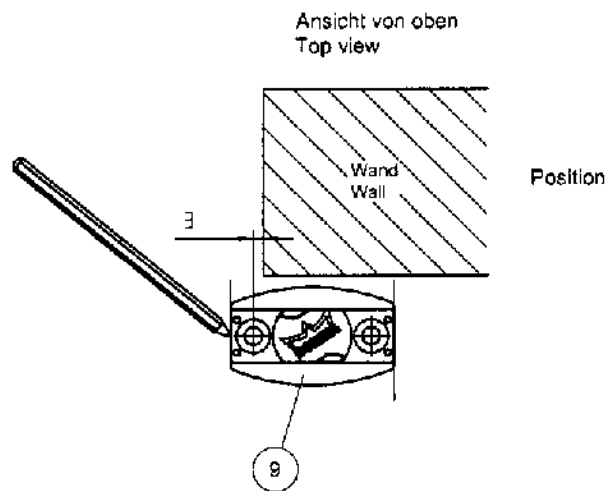
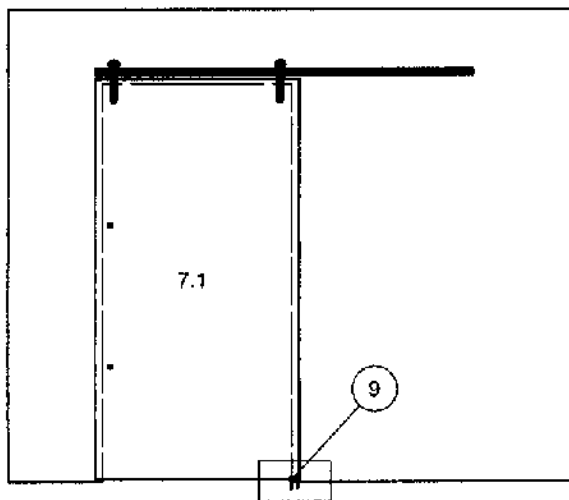

7. Bodenführung montieren:
7. Mounting of the floor guide:

7.2 Schiebetür aushängen und Bohrungen markieren
 7.2 Lift out sliding door and mark the holes

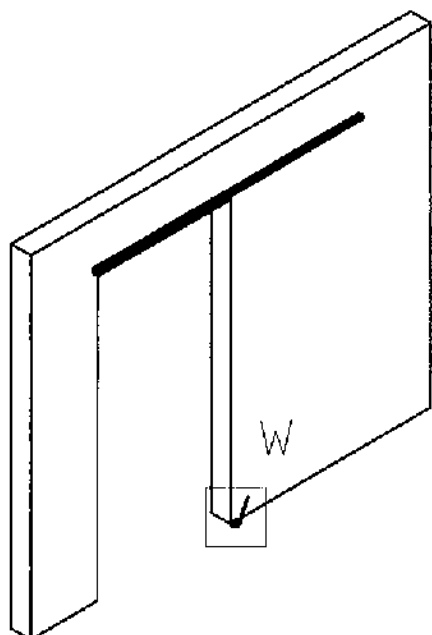

Detail W

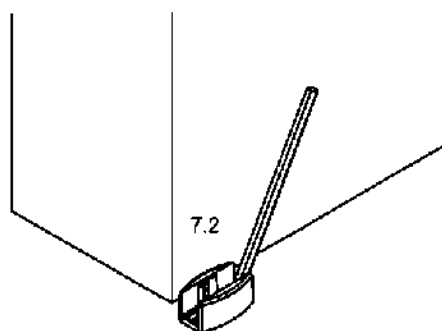

7.3 Bohren der Löcher
 7.3 Drilling the holes

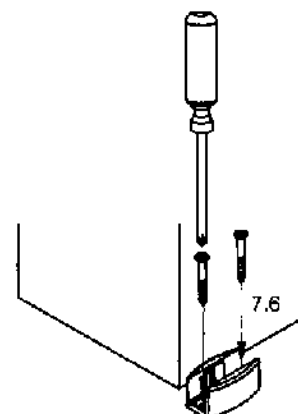
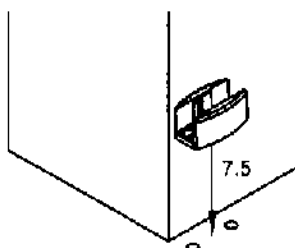
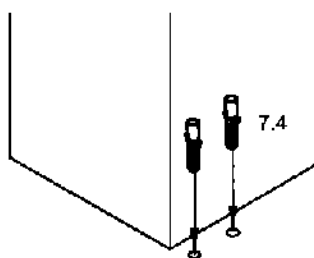
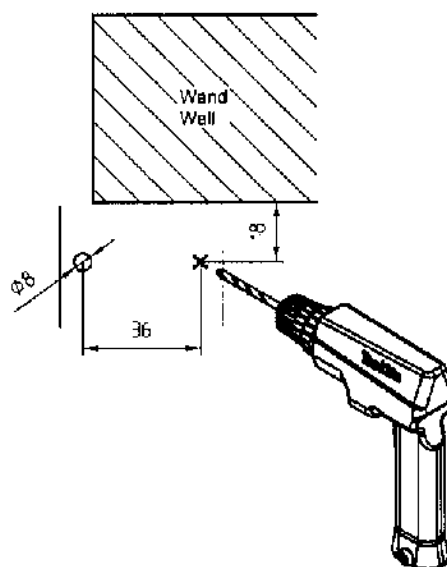

8. Türstopper montieren:
8. Mounting of the door stoppers:

8.1 Schiebetür einhängen
 8.1 Fit sliding door

8.2 Tür vollständig schließen
 8.2 Close the door completely

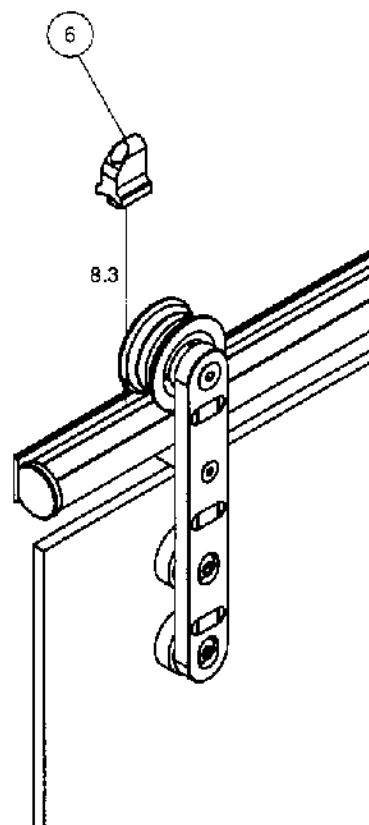
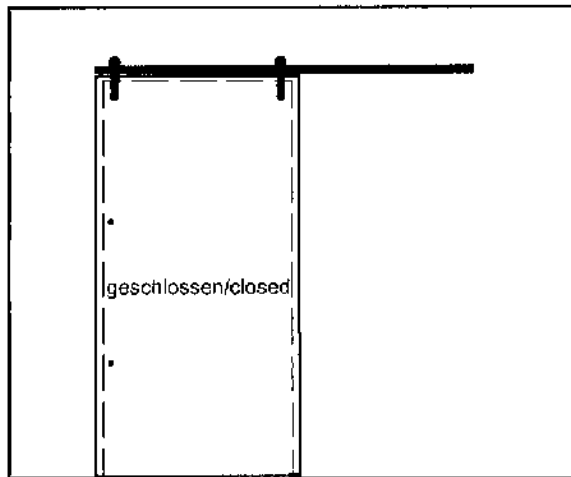

8.4 Tür vollständig öffnen
 8.4 Open the door completely

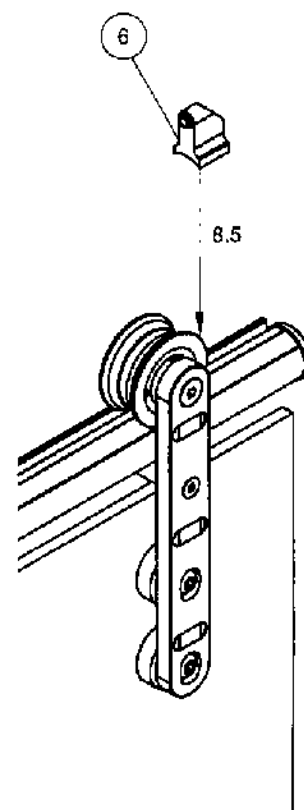
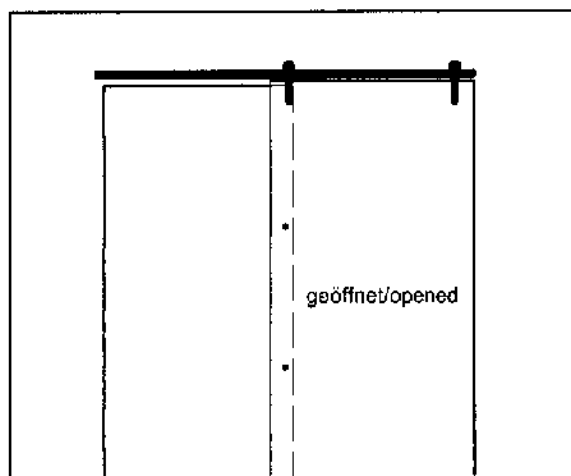

8. Tüstopper montieren:
8. Mounting of the door stoppers:

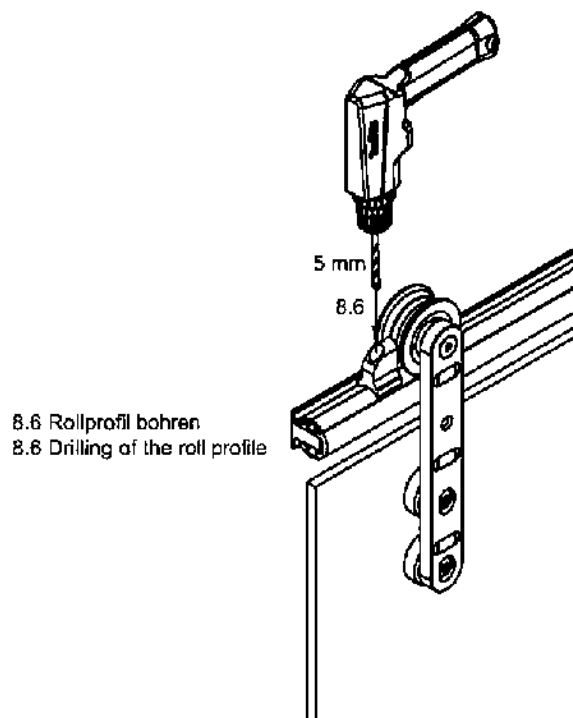

Nur das Kunststoffprofil bohren.
Only drill the plastic profile.

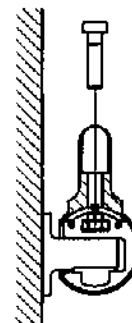
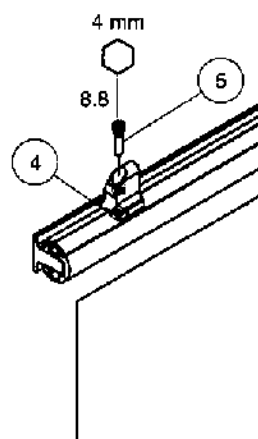
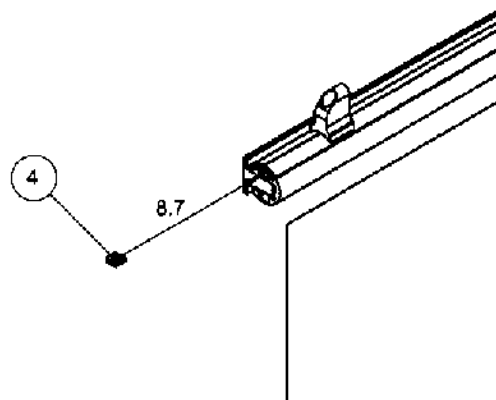

9. Abdeckkappen befestigen:

9. Fasten of the cover caps:

9.1 Folienstreifen (7.1) abziehen und Kappen (7) aufkleben

9.1 Pull off backing tape (7.1) and stick on the cover caps (7) into right place

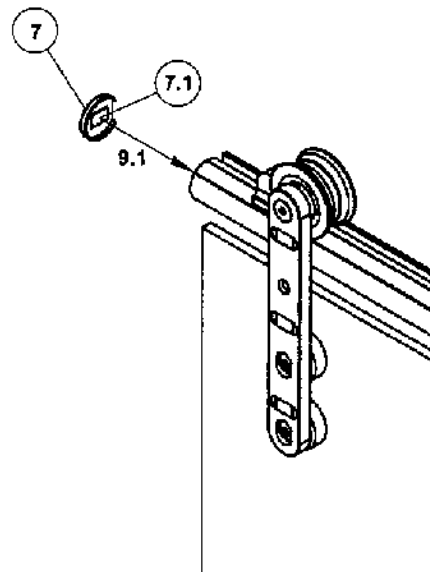

10. Aushebeschutz montieren:

10. Mounting of the antijump mechanism:

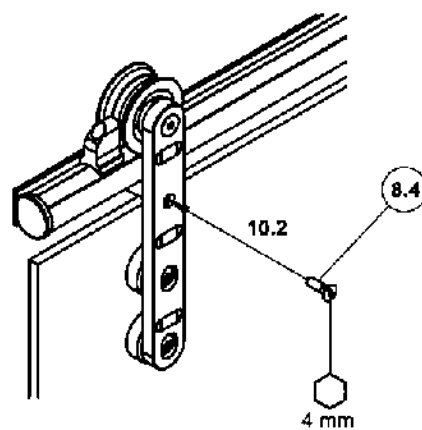
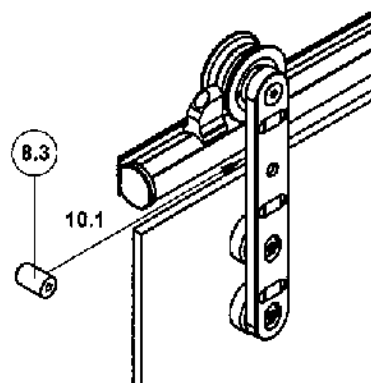

**11. Tür einstellen:
11. Adjusting of the door:**

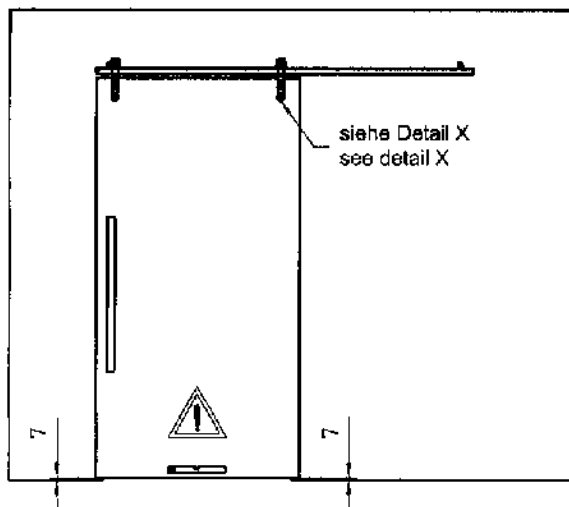

Detail X

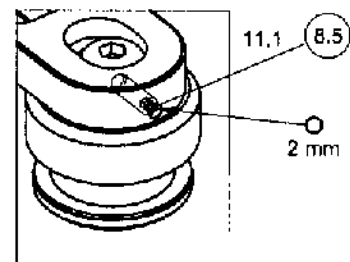

11.1 Justieren der Punkthalter mit Hilfe des Gewindestifts

11.1 Adjust the single-point fixings via the setscrew

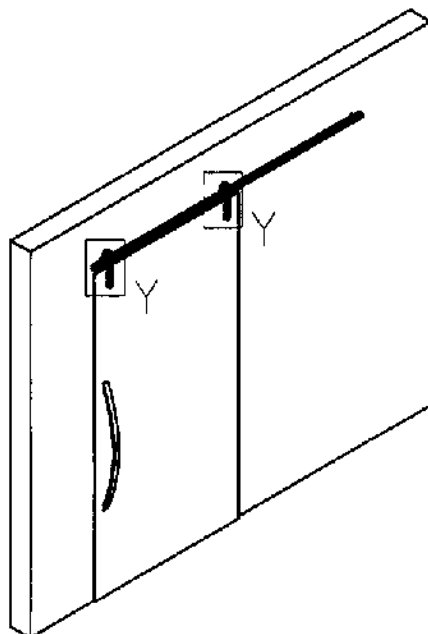

Detail Y

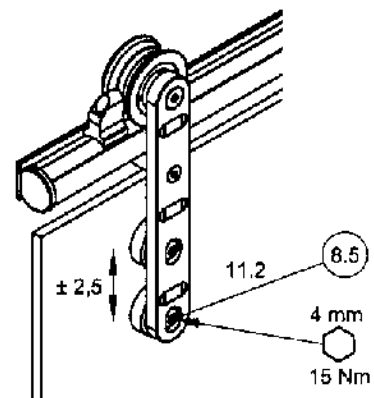

**12. Abdeckkappen auf Rollenwagen montieren:
12. Mounting of the cover caps on roller:**

12.1 Folienstreifen (8.6) abziehen und Kappen (11) aufkleben

12.1 Pull off backing tape (8.6) and stick on the cover caps (11) into right place

