

# ASSEMBLY INSTRUCTION

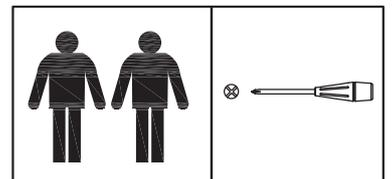

## Warning:

1. The maximum static loading weight is 220lb and the dynamic loading weight is 11-18lb!
2. The desk can not lift up by itself at the first time after placing some times or temperature is too low , you have to give a little pull force by hands to help it lift up!
3. The desk have potential danger of tip-over if don't use it wisely, so children need to be accompanied by adult.



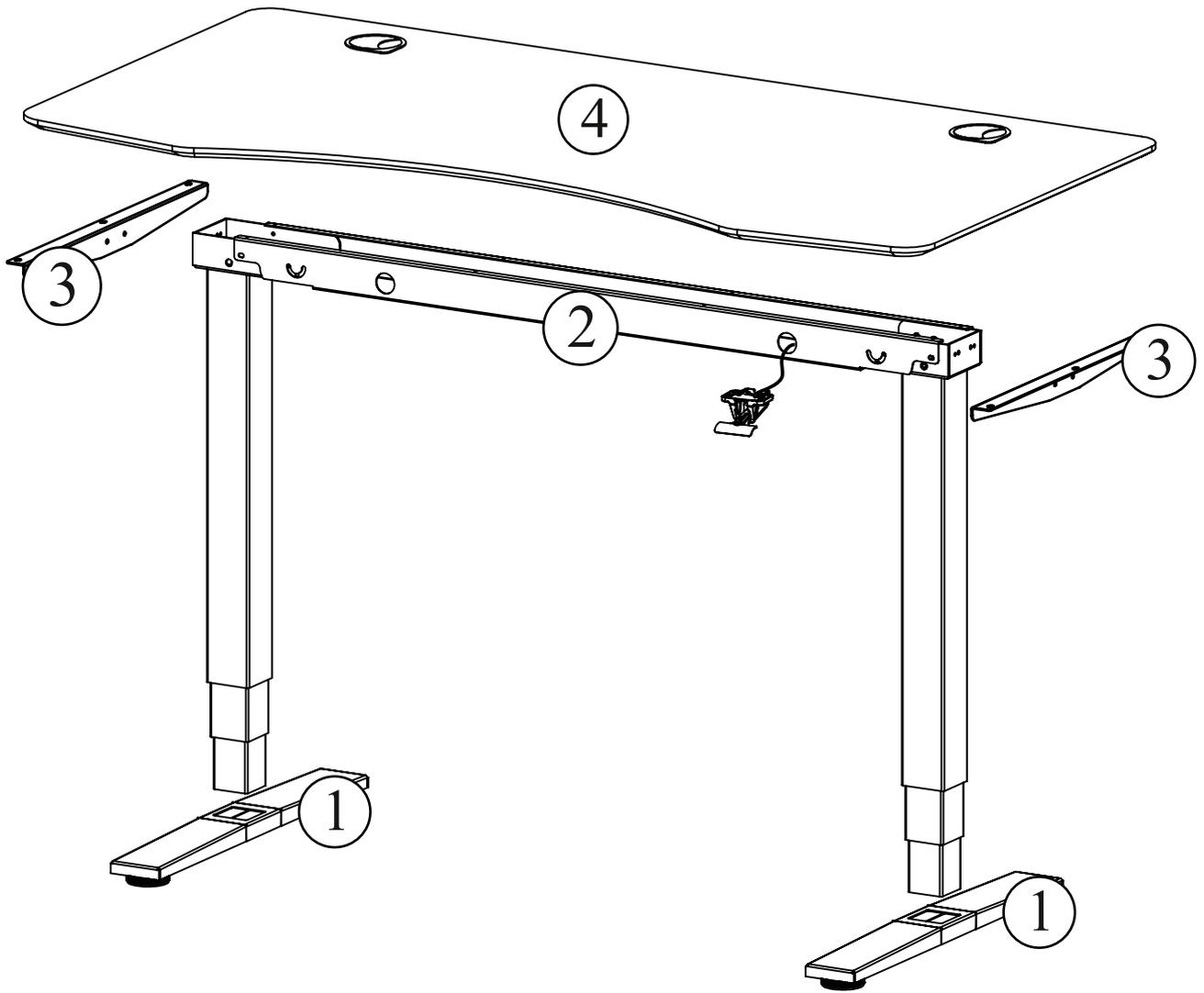

	Ax4			Bx16	M6x12mm
	Cx6	M6x25mm		Ex1	
	Gx1	4MM			

1



**Warning Hands Pinching**

Do not place your hand near the here. The angle changes during the installation will hurt you.

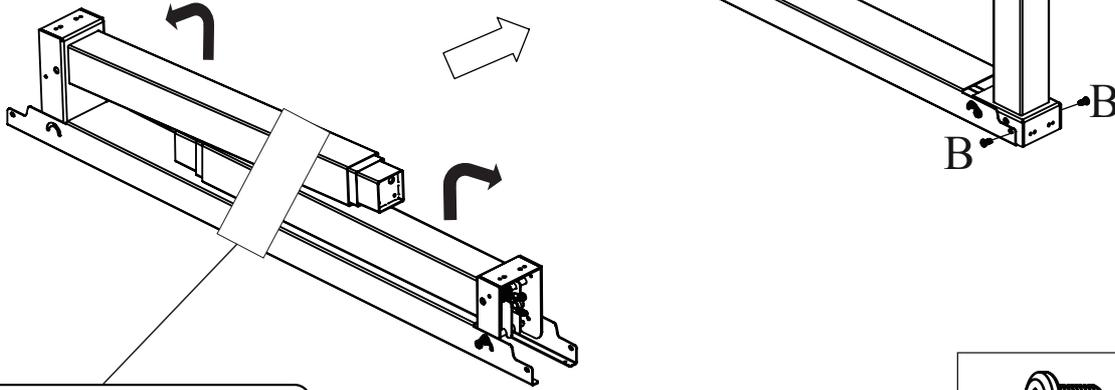

Do not cut off tape before open frame.



Bx4



Gx1

2

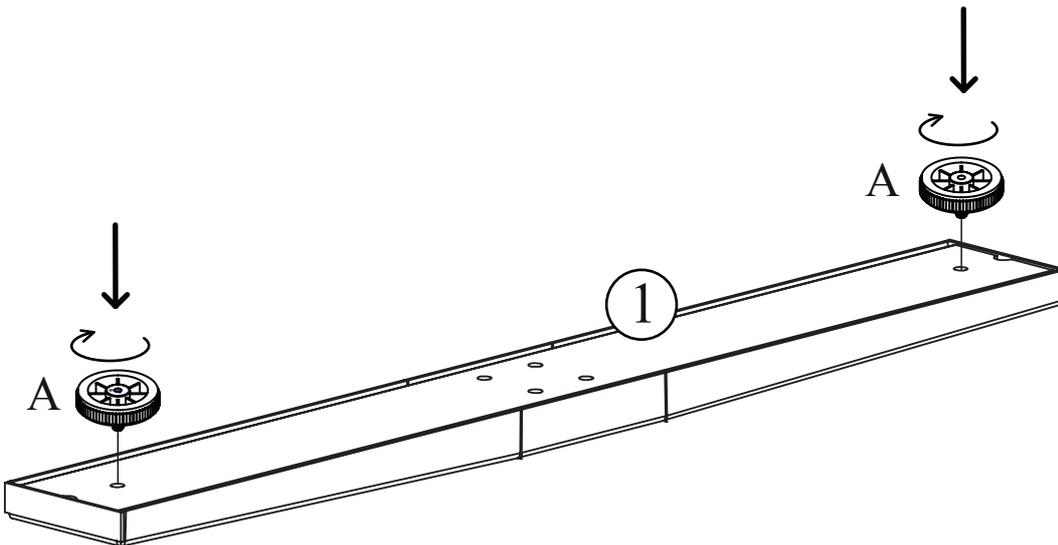

Ax4

3

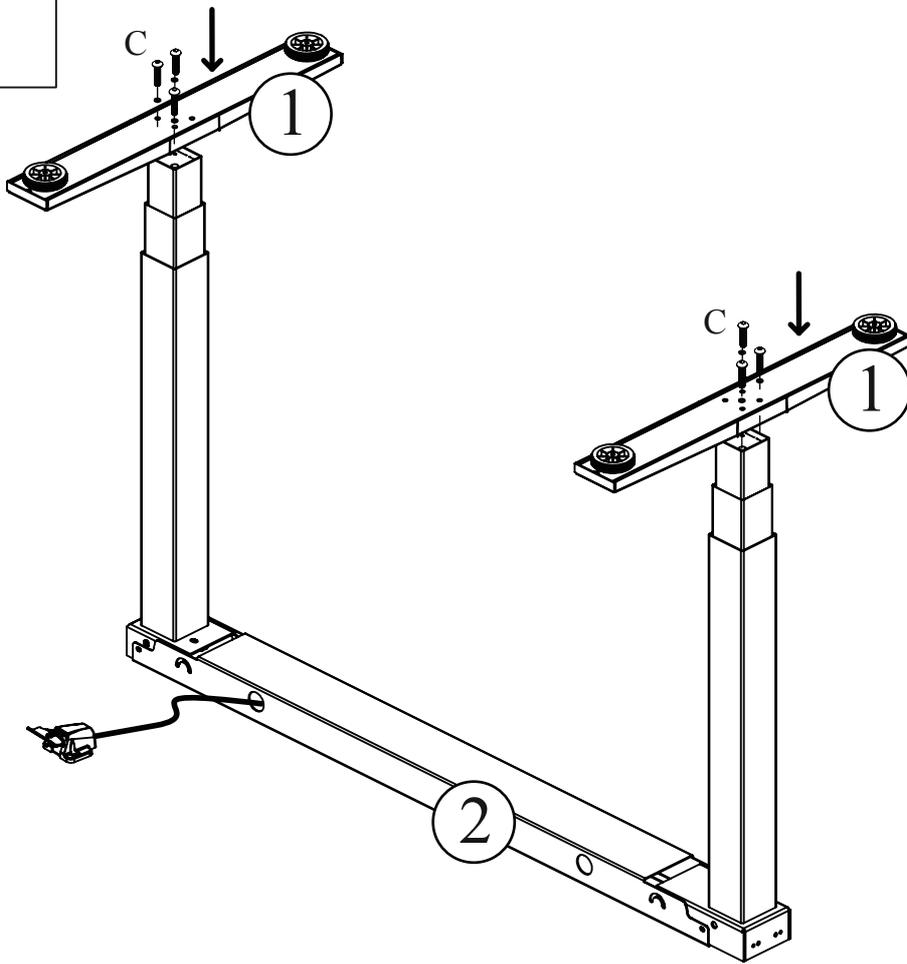

Cx6



Gx1

4

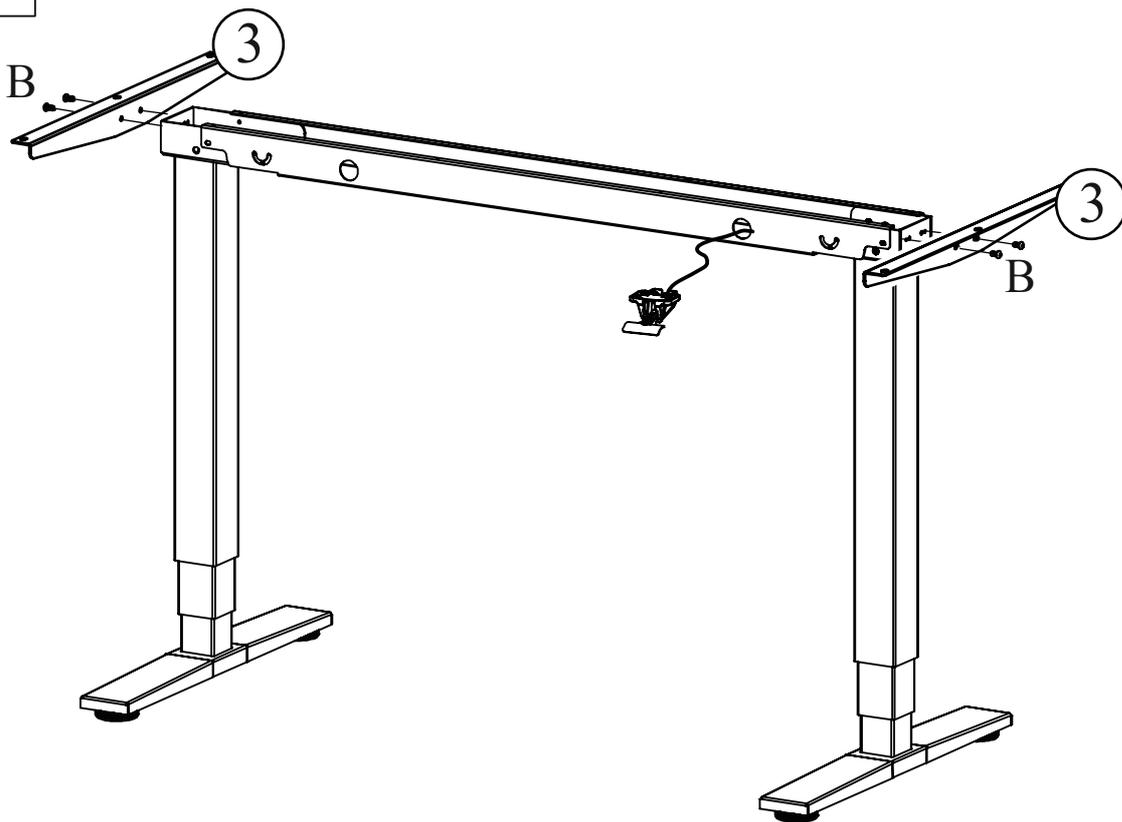

Bx4



Gx1

5

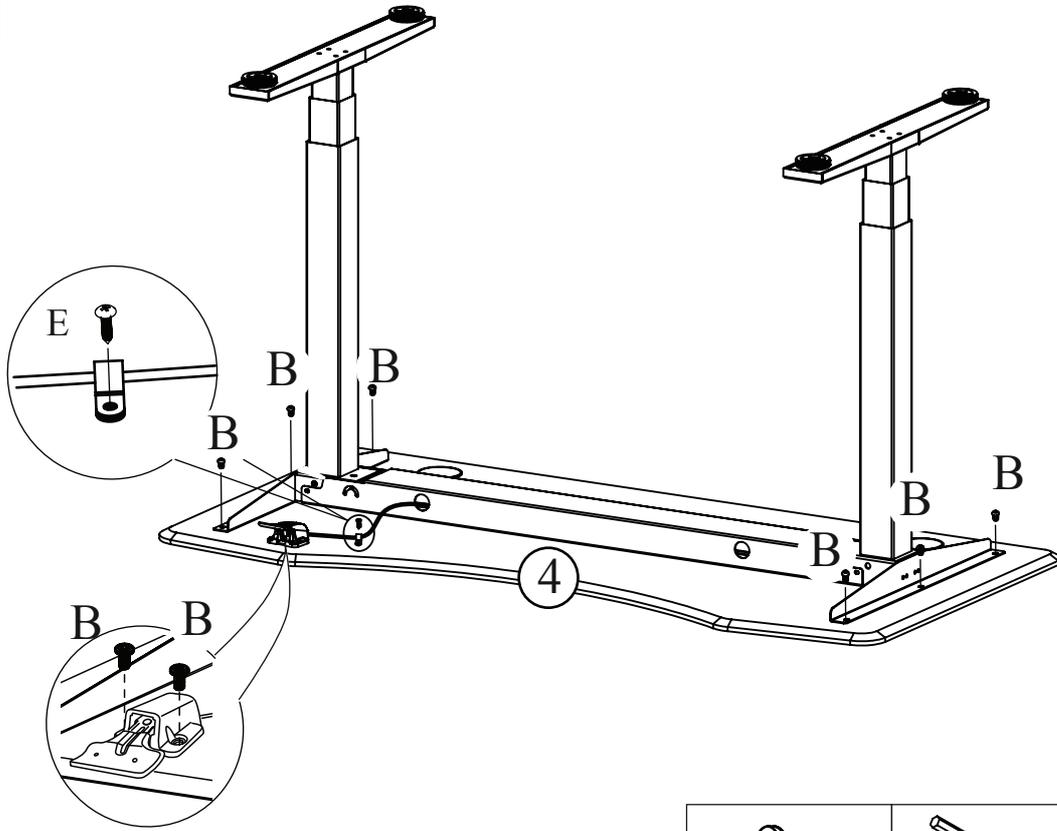

 Bx8	 Gx1	 Ex1
---	--	--

6

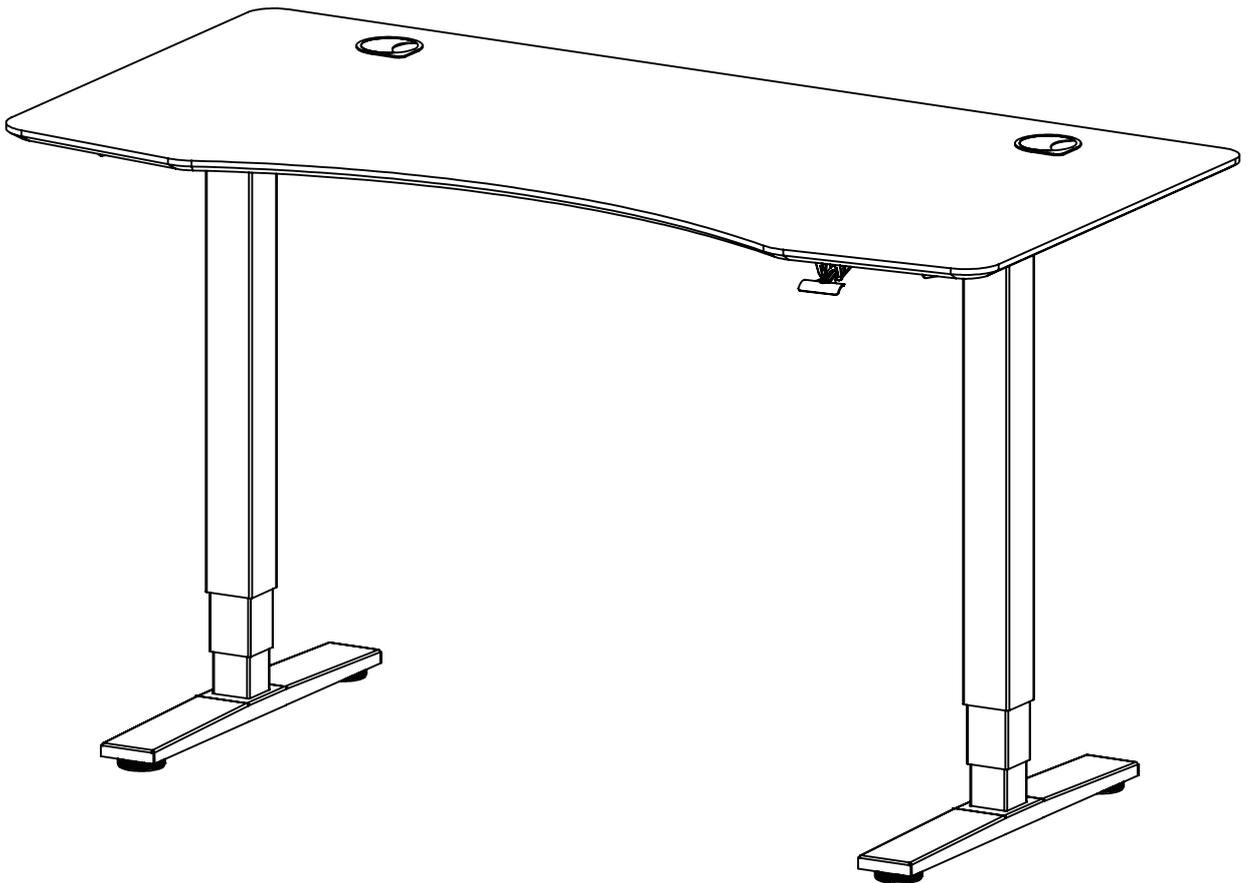

# Operating Manual

< 15KG

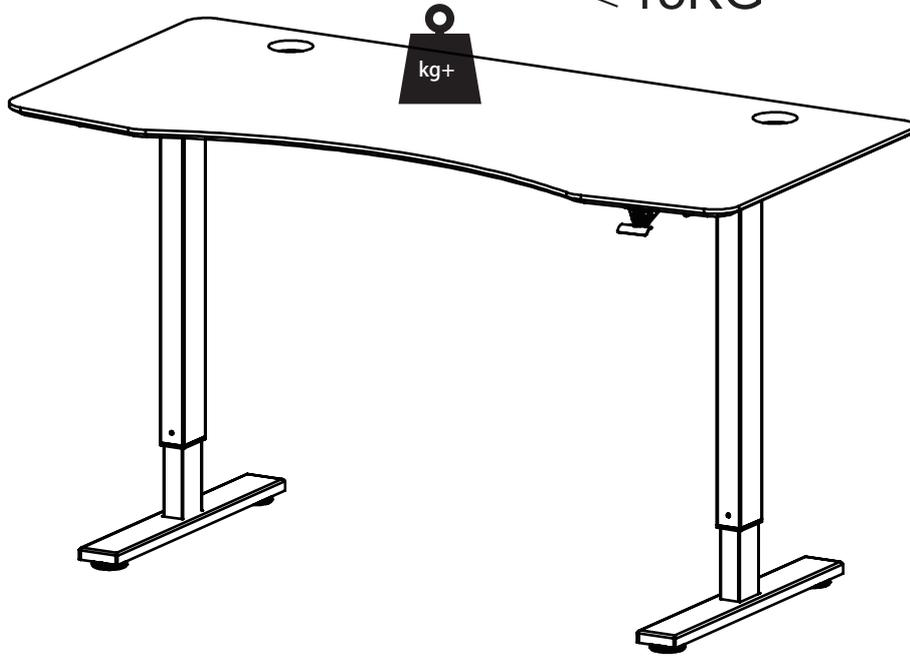

Attention: it is recommended not to exceed a maximum of 15KG on desk top to allow for easy lifting.

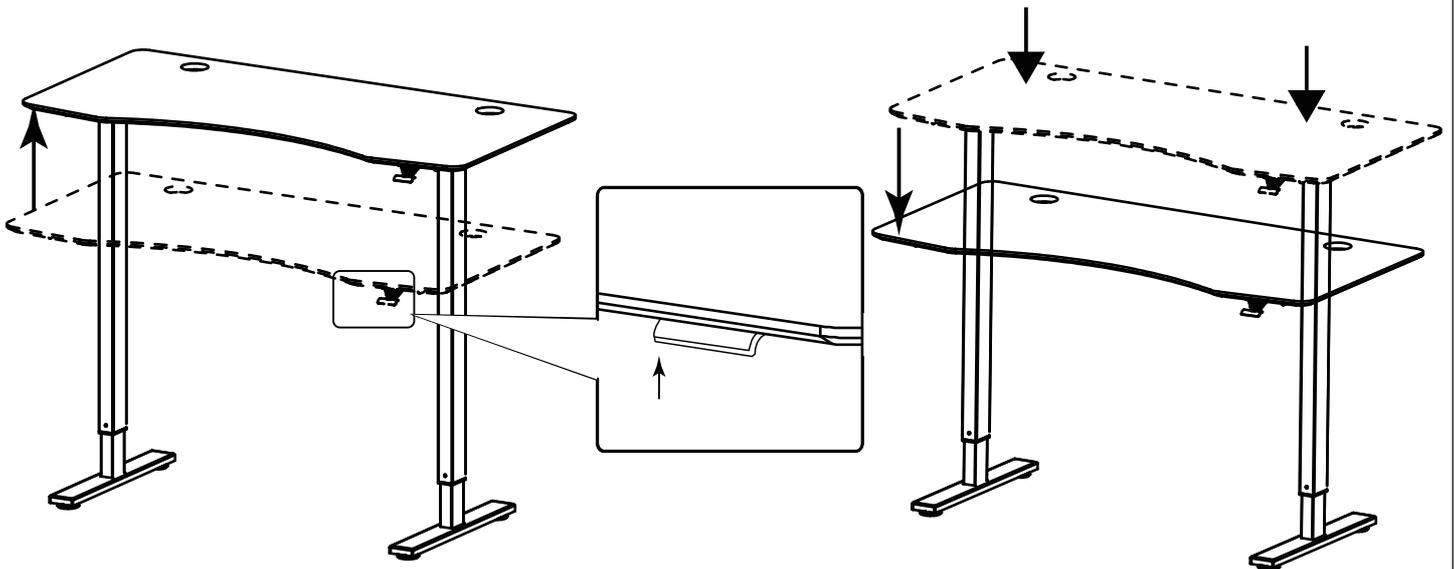

Lift the paddle for lifting the table top.

Lift the paddle and press the table top for downward operation.