



IN.21.900
LOCKING SYSTEMS

AUTOMATIC OVERHEAD DOOR CLOSER
MOLA DE PORTA AEREA AUTOMATICA
CIERRA PUERTAS AEREO AUTOMATICO



WARNING

**IT MIGHT CAUSE DAMAGE TO THE PROPERTY OR INJURY TO THE USER UNDER THE INCORRECT USAGE.
IT MIGHT CAUSE A SERIES INQUIRY OR DEATH UNDER INCORRECT USAGE.**

1. GENERAL SAFETY INSTRUCTION	
1.1. INTRODUCTION	04
1.2. OVERVIEW	04
1.3. GENERAL NORMS	04
1.4. WARRANTY	04
1.5. DISPOSAL AND RECYCLING	04
2. PRE-INSTALLATION	
2.1. INSTALLATION REQUIREMENTS	05
3. TECHNICAL DATA	
3.1. FEATURES	05
3.2. TECHNICAL DATA	06
3.3. DIMENSIONS	06
3.4. COMPONENTS	07
3.5. OPTIONAL ACCESSORIES	07
3.6. MECHANISM COMPONENTS	08
4. MECHANICAL INSTALLATION	
4.1. BAR TYPE	09
4.1.1. PULL BAR - OPEN TO INSIDE (MECHANISM INSIDE)	09
4.1.2. PUSH BAR - OPEN TO OUTSIDE (MECHANISM INSIDE)	09
4.2. INSTALLATION OF BOTTOM PLATE	10
4.2.1. PULL BAR	10
4.2.2. PUSH BAR	11
4.3. INSTALLATION OF SLIDING ARM	12
4.3.1. PULL BAR	12
4.3.2. PULL BAR FOR GLASS DOOR	13
4.3.3. PUSH BAR	13
4.3.4. PUSH BAR FOR GLASS DOOR	14
4.4. MECHANISM INSTALLATION	16
4.5. ASSEMBLE AND DISASSEMBLE OF THE MECHANISM UP COVER	16
5. WIRED DIAGRAM	
5.1. TERMINAL DETAILS	17
5.2. INTERLOCK	18
5.3. 24G MICROWAVE SENSOR (IN.15.731)	18
5.4. DIFFERENT SENSOR EXAMPLE	19
5.5. DIFFERENT SENSOR (EXAMPLE: IN.15.730)	19
5.6. MAGNETIC LOCK	19
5.7. ANTI-CLAMP SENSOR (EXAMPLE: IN.15.737)	20
5.8. ANTI-CLAMP SENSOR (EXAMPLE: IN.15.730)	20
6. REMOTE CONTROL	
6.1. OPERATION OF THE REMOTE CONTROL	21
7. DATA SETTING	22
8. LED DISPLAY FEEDBACK	
8.1. SINGLE OPENING	22
8.2. DOUBLE OPENING	22
9. TROUBLESHOOTING	23

1.1. INTRODUCTION

Dear client:

We thank you for your confidence in JNF for acquiring this innovative automatic overhead door closer. JNF offers products designed and developed following high demanding production standards, to ensure we deliver a product with the best quality, as well as a superb user friendly experience and easy installation. This manual includes important and necessary information for the correct and safe installation, use and maintenance of this sliding door system. Please, read these instructions in full before starting the installation.

1.2. OVERVIEW

This manual is applicable to the installation, use and maintenance of the IN.21.900, which is designed for being used indoors. The section in this manual related to installation and commissioning, is limited only and exclusively for use by qualified skilled technicians

1.3. GENERAL NORMS

JNF declines all civil or criminal liabilities for injuries caused to persons, animals and/or objects as a result of:

- A.** Not proceeding following the indications contained in the installation, user and maintenance manuals.
- B.** A non-authorized manipulation of the product.
- C.** The replacement of parts and/or pieces of the operator, as well as the use of accessories which are not original, or which have not been homologated by the manufacturer.
- D.** Removing, deleting or altering the stickers, labels and/or other indications placed in origin, on the automatic door operator or its accessories.
- E.** Standing within the course of the door leaf of the automatic door, or performing tasks near possible parts in motion.

1.4. WARRANTY

The manufacturer's warranty for the IN.21.900 will be **VOID** if:

- A.** The installation, use and/or maintenance of the product did not follow the norms, instructions and indications described in this manual.
- B.** Using non-original components, accessories, parts, pieces or electronics systems, being these new or for replacement purpose, when these parts haven't been supplied or homologated by the supplier.

1.5. DISPOSAL AND RECYCLING

When disposing the packaging materials, it is recommended to check the specific regulation in force at the installation site, before proceeding to dispose it. Packaging materials are similar to other urban solid waste materials, and therefore they can be easily disposed after doing a selective classification and recycling.

When the product needs to be disposed, as this is composed of different materials, we recommend:

- A.** Materials such as aluminium, plastic, steel, electrical cables (etc) are solid waste materials, which need to be carefully classified for a proper recycling in authorized recycling centres.
- B.** Other components such as the plates of electronic circuits, capacitors, batteries, magnets (etc) may contain contaminating materials, and as such, they must be carefully removed and delivered to companies specialized in their evacuation, classification and disposal.

DO NOT THROW AWAY THE PACKAGING OR PRODUCT MATERIALS ANYWHERE. RECYCLE!!

2.1. INSTALLATION REQUIREMENTS

For a good performance, the operator must be levelled in all 3 axis, and be firmly fixed to a solid vertical surface.

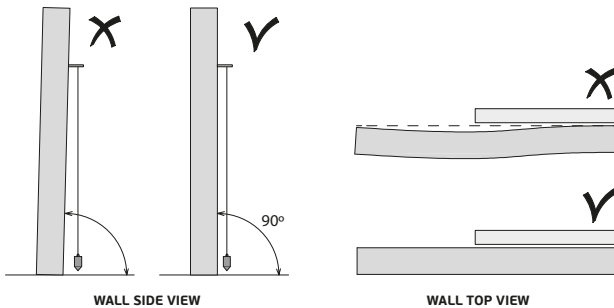

3. TECHNICAL DATA

3.1. FEATURES

- A.** Suitable for wooden doors, metal doors, frame door
- B.** Opens to one direction (both single or double open)
- C.** Special glass clamp is request for glass door installation
- D.** Adjustable speed/opening time/open degree/close force
- E.** Door width: <=1600mm
- F.** Door weight: <=140Kg
- G.** Open degree: 60-115 adjustable
- H.** Installation: open to inside/open to outside (pull/push bar)
- I.** Voltage: AC220V/110V, Input 220V AC - Output 24 DC
- J.** Open device: wireless push button/remote control
- K.** 2000000 service life test, super reliable
- L.** 55w high speed dc brushless motor, long service life, low noise.
- M.** Control chip, reliable performance, digital display design, mechanism is easy to adjust and fine adjust is allowed.
- N.** In main and slave mode. Sequence will not change because of encounter an obstacle.
- O.** Double gear box design, high speed ratio, high strength, can work with 140kg door (works with E-lock for a safer use)
- P.** PUSH&GO function.
- Q.** Certified transformer. 220V/110V, Power 50w.

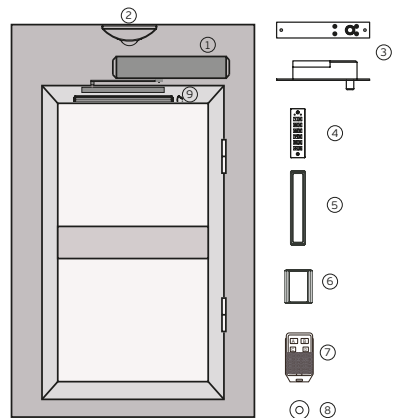

CAPTION

1. SWING DOOR MECHANISM
2. MICROWAVE SENSOR
3. E-LOCK
4. NUMBER KEYPAD
5. PUSH BUTTON (WIRELESS)
6. TOUCHLESS SENSOR
7. REMOTE CONTROL
8. PUSH BUTTON
9. TOP SENSOR

3.2. TECHNICAL DATA

SIZE	515x80x115mm
WEIGHT	8kg
WORKING TEMPERATURE	-20 °C ~ +50 °C
INPUT VOLTAGE	AC 200 -250V
OUTPUT VOLTAGE	24V DC (+/- 10%), 3A
OPEN DEGREE	Max 115°
OPEN SPEED	45°/s
CLOSE SPEED	45°/s
OPENING TIME	0-60 s (adjustable)
PROTECTION CLASS	IP21

NOTES:

Data recorded under zero wind pressure.

Door leaf over weight is not allowed, service life will get shorter.

3.3. DIMENSIONS

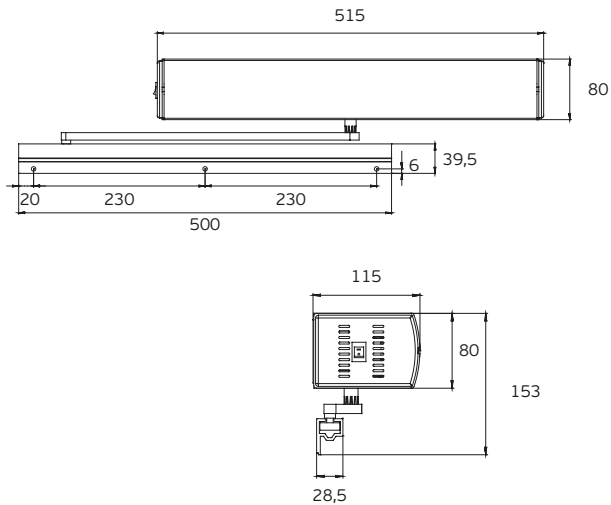

3.4. INCLUDED COMPONENTS



DOOR CLOSER MECHANISM



REMOTE CONTROL

3.5. OPTIONAL ACCESSORIES



MICROWAVE SENSOR
IN.15.731



TOP SCAN
IN.15.737



DOUBLE ACTION SENSOR
IN.15.730



SLIDING ARM
IN.21.902.A



STANDARD ARM
IN.21.902.B



SLIDING ARM FOR GLASS
IN.21.902.C



GLASS CLAMP FOR PUSH ARM
IN.21.903



E-LOCK
IN.28.501



TOUCH SWITCH
IN.24.207



NUMERIC KEYBOARD
IN.28.108



NUMERIC KEYBOARD
IN.28.109



WIRELESS PUSH BUTTON
IN.15.732



TOUCHLESS SWITCH
IN.21.910



WIRELESS TOUCHLESS SWITCH
IN.21.910.WL

(*) WIRELESS RECEIVER
(*) OPTIONAL / NOT NEEDED FOR THIS SYSTEM
(*) IN.21.910.RC

3.6. MECHANISM COMPONENTS

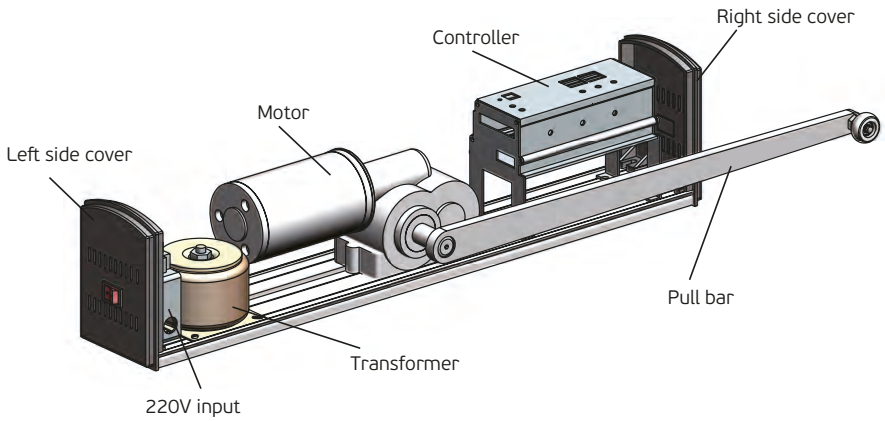

BOTTOM PLATE



PULL BAR

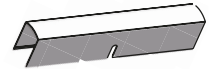

COVER



PULL GUIDER

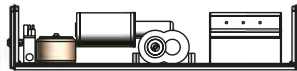

MECHANISM

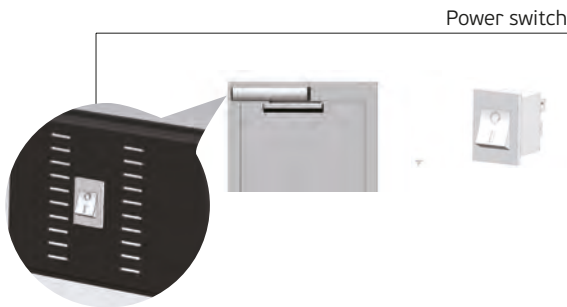

4.1. BAR TYPE

4.1.1. PULL BAR - OPEN TO INSIDE (MECHANISM INSIDE)

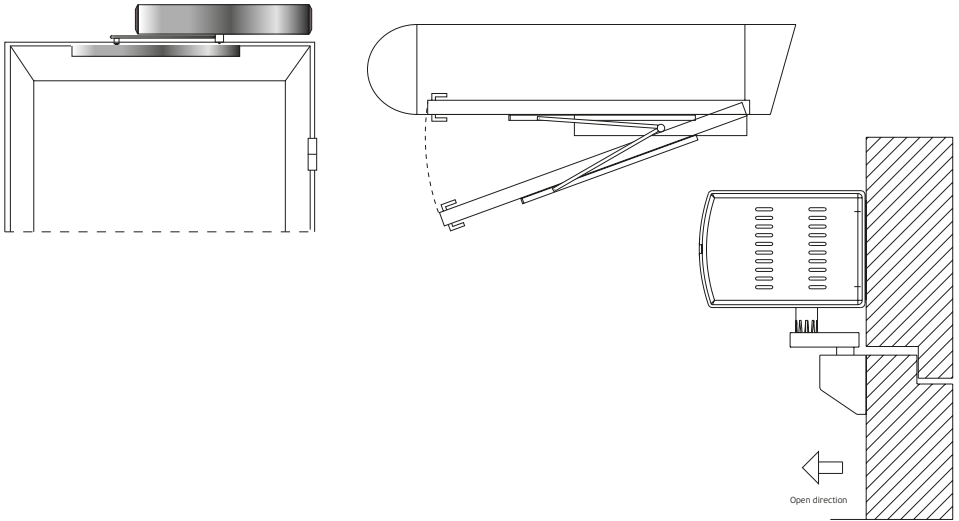

4.1.2. PUSH BAR - OPEN TO OUTSIDE (MECHANISM INSIDE)

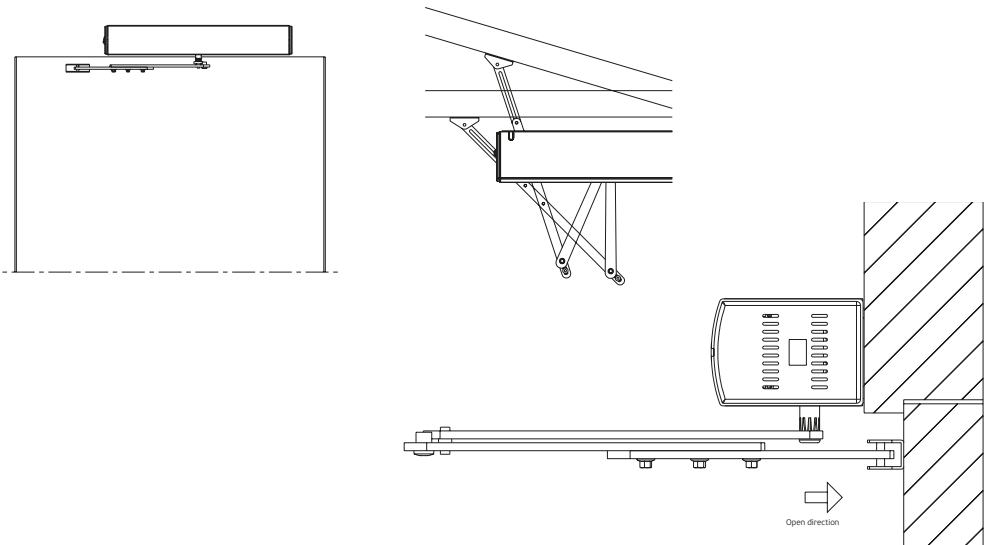

4.2. INSTALLATION OF BOTTOM PLATE

4.2.1. PULL BAR

① Right side installation

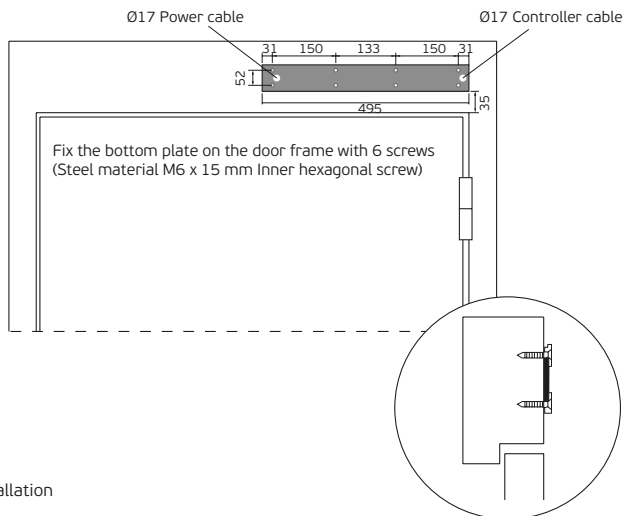

② Left side installation

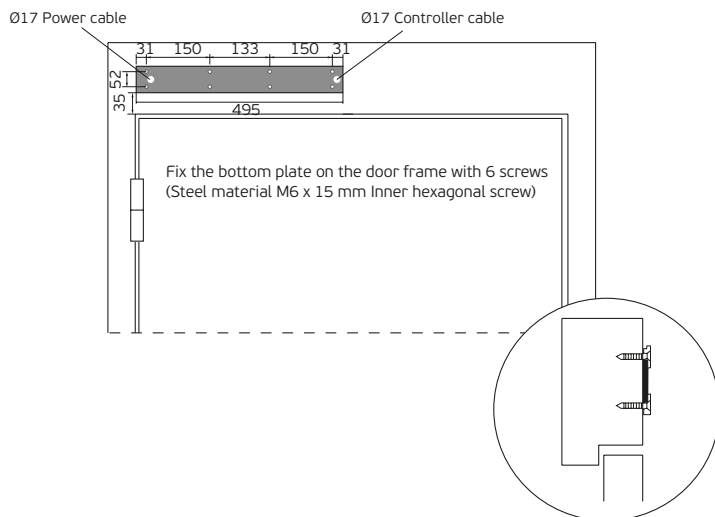

4.2.2. PUSH BAR

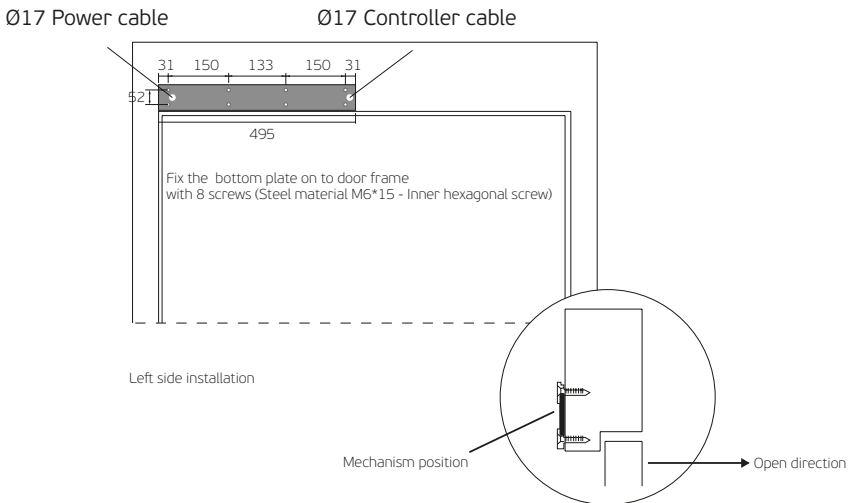
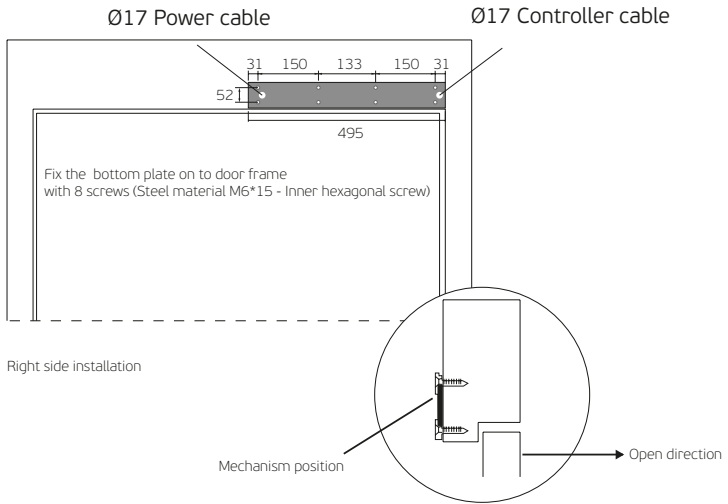

Tip:
 For push bar installation, the mechanism and open direction are the same.
 For pull bar installation, the mechanism and open direction are opposite.

4.3. INSTALLATION OF SLIDING ARM

4.3.1. PULL BAR

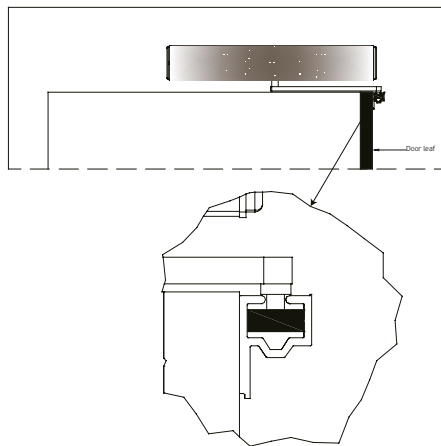
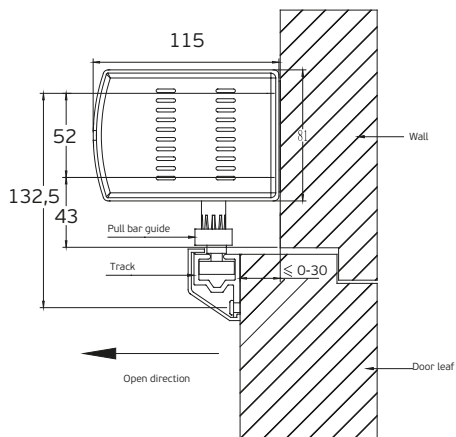

1. Open the door to a 90° angle. Slide the pull guide roller into the track
2. Fix the pull bar plate as shown
3. Move the plate to ensure the wheel is at the middle position of the track as shown
4. Hold the plate position and fix the first screw near the center of the shaft
5. Close the door and repeat STEP 3 and then fix another screw at the other side
6. Manually move the door to ensure the pull bar works smoothly. Adjustment is requested if there is any resistance during the operating
7. Fix the last screw

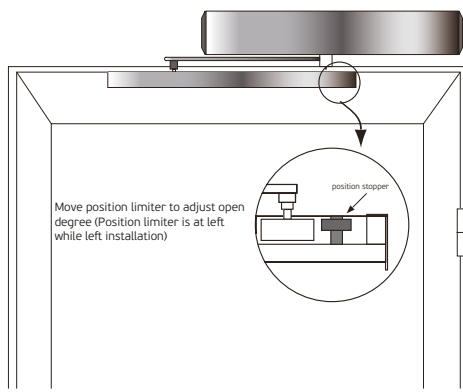
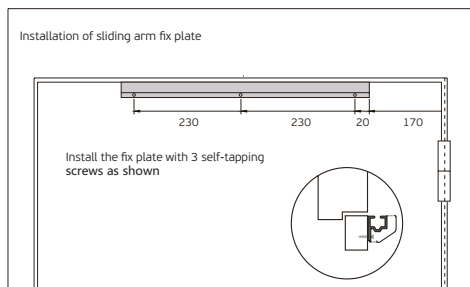

4.3.2. PULL BAR FOR GLASS DOOR

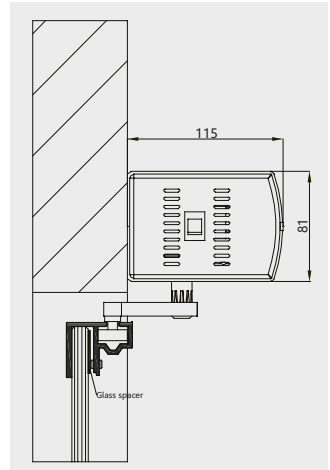
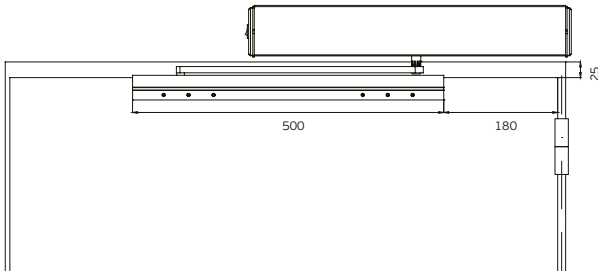

TIP:
Ensure 25mm space for the glass top to door frame bottom (glass door installation)

4.3.3. PUSH BAR

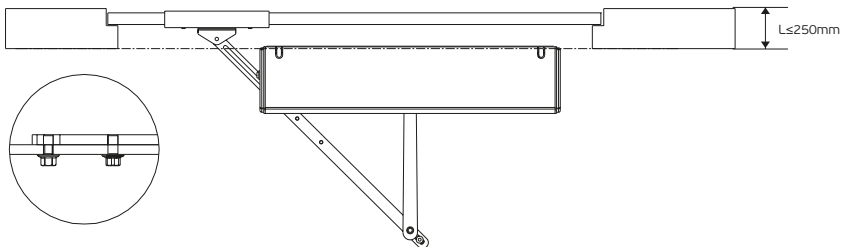
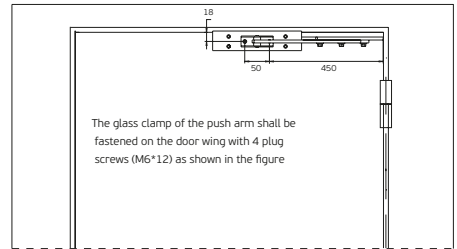
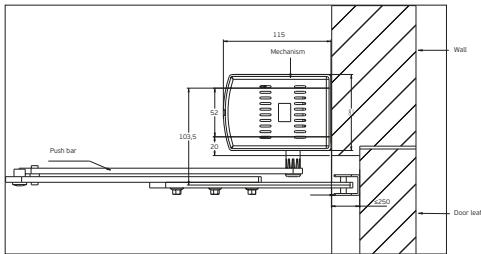

Adjust the push bar length by two screw according to the door frame's depth(L).

Automatic door right installation

4.3.4. PUSH BAR FOR GLASS DOOR

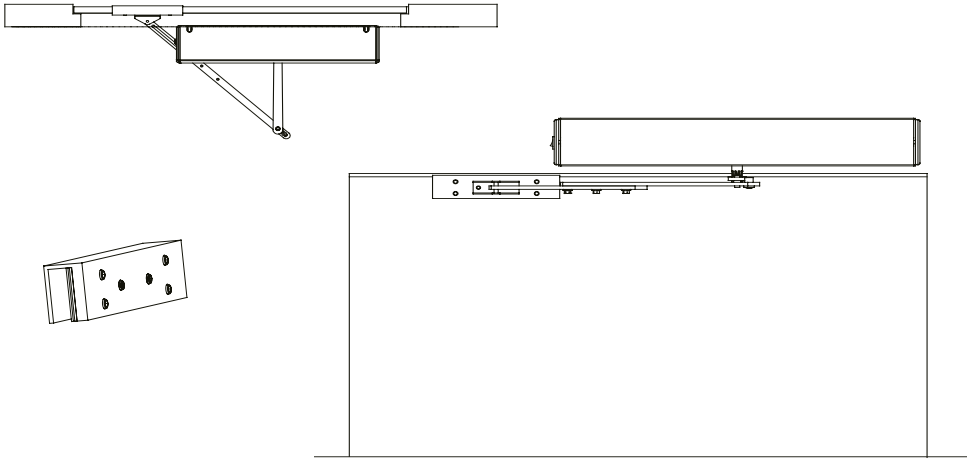
**NOTE:**

Make sure there is a 10mm gap between the top of the glass and the bottom of the door when using the push arm of the glass door

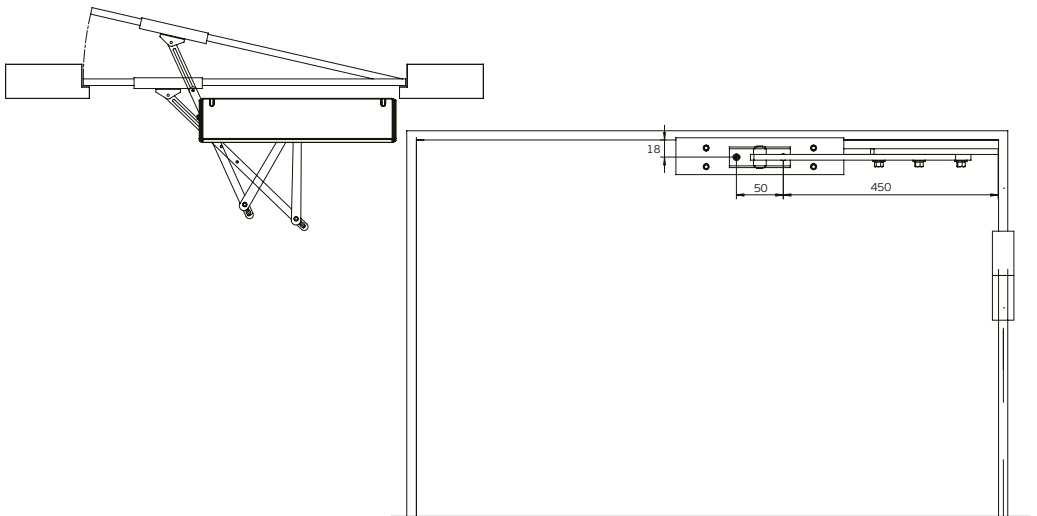
**NOTE:**

The glass clamp of the push arm shall be fastened on the door wing with 4 plug screws (M6x12) as show in the image

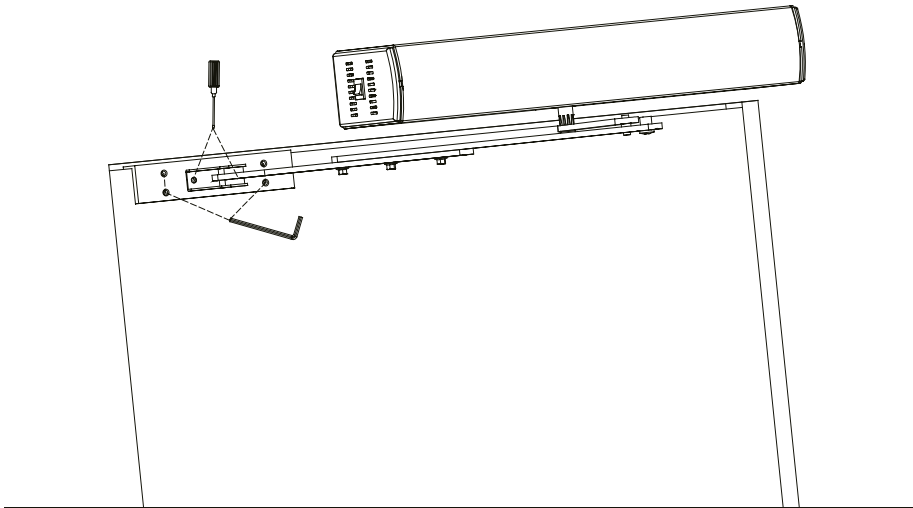

Fix the glass clamp and spacer with 4 screws (M6x12) tightly on the glass door. Install the fix plate of the push bar with 2 screws 8M5x8) on the glass clamp.

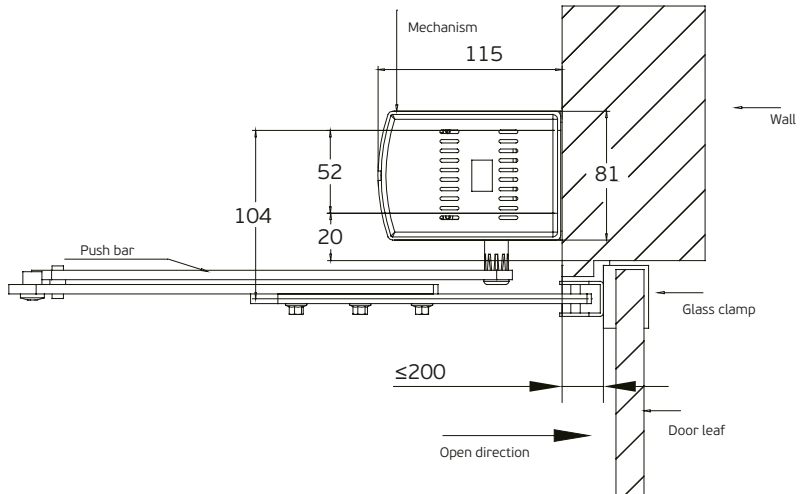

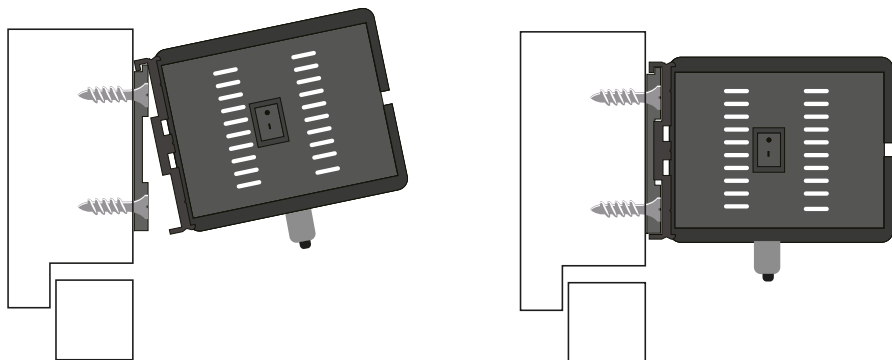
4.4. MECHANISM INSTALLATION

Hang the mechanism on the fixed base cover with screws.

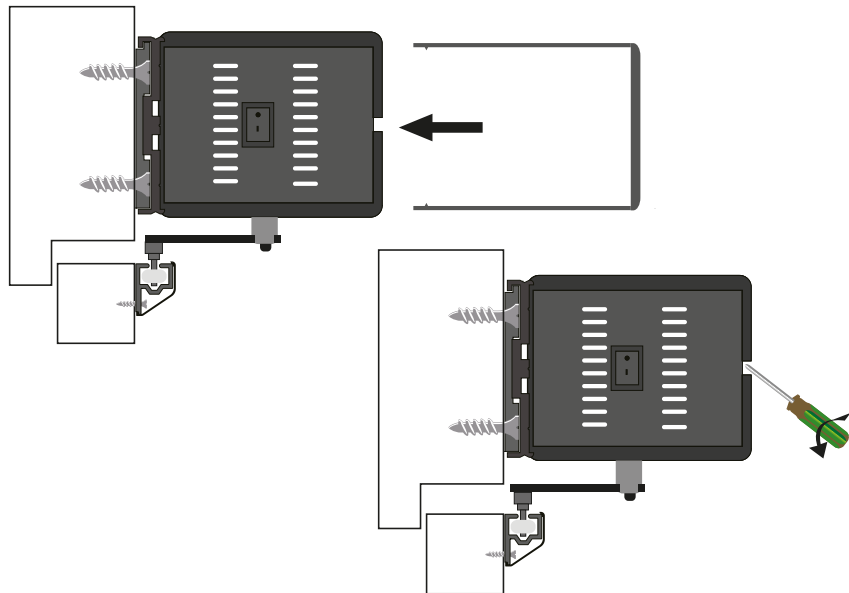
4.5. ASSEMBLE AND DISASSEMBLE OF THE MECHANISM UP COVER

5.1. TERMINAL DETAILS



- | | |
|-----------------------|----------------------------|
| 1. +24V | 13. SYNCHRONOUS (IN) |
| 2. GND | 14. INTERLOCK (OUT) |
| 3. +12V | 15. COM |
| 4. GND | 16. INTERLOCK (IN) |
| 5. OPEN - A | 17. E-LOCK + |
| 6. COM | 18. GND |
| 7. FULL LOCK | 19. UPS + |
| 8. COM | 20. +24V |
| 9. OPEN - B | 21. +12V |
| 10. COM | 22. GND |
| 11. SYNCHRONOUS (OUT) | 23. ANTI-COLLISION (CLOSE) |
| 12. COM | 24. ANTI-COLLISION (OPEN) |

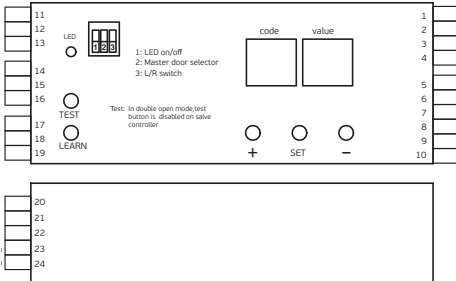

Press the **+** or **-** button to find the code you want to adjust.
 Press the **SET** button and the LED light will flash. Then press the **+** or **-** button to adjust the value of the code. At last, press the **SET** button, the LED light will stop flashing. Date setting is finished.

CONNECTION OF THE POWER SUPPLY FOR SINGLE OPEN

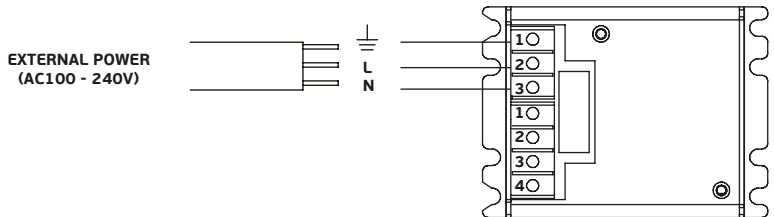

CONNECTION OF THE POWER SUPPLY FOR DOUBLE OPEN

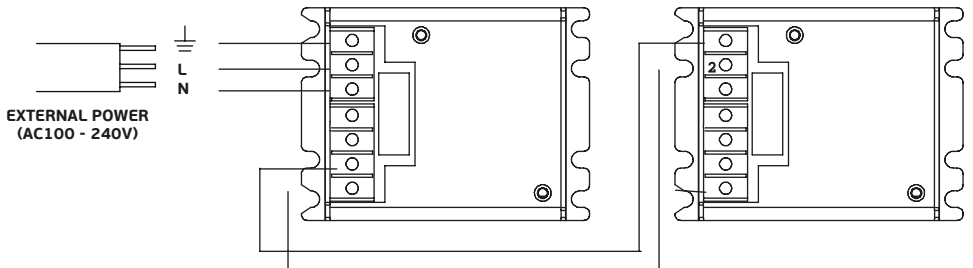

5.2. INTERLOCK CONTROL WHEN THE DOOR CLOSES - MASTER / SLAVE



SYNCHRONOUS CONTROL WHEN THE DOOR OPENS - MASTER / SLAVE



TIP: Er03 means synchronous cable is not well connected

IN SINGLE OPEN MODE BRIDGE CONNECTS TERMINAL 11 AND 13



5.3. 24G MICROWAVE SENSOR (IN.15.731)

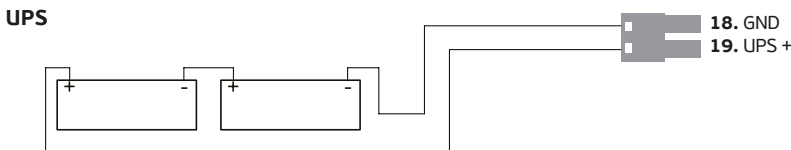
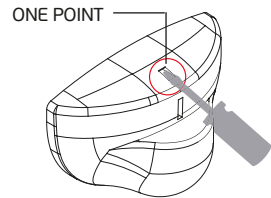
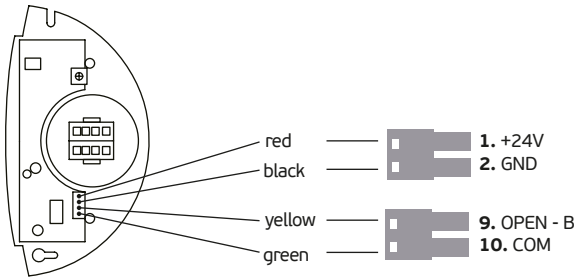

5.4. DIFFERENT SENSOR EXAMPLE

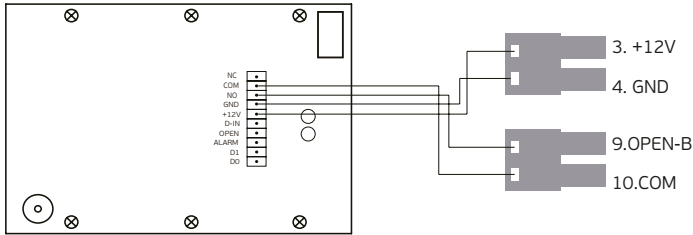

5.5. DIFFERENT SENSOR (EXAMPLE: IN.15.730)



5.6. MAGNETIC LOCK / E-LOCK

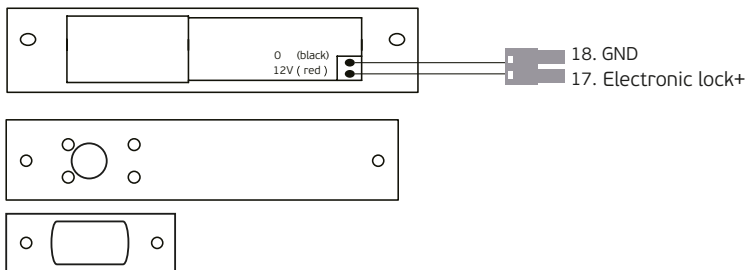

TIP:

The magnetic lock should connect with the power access. The lock current should be lower than 800mA

5.7. ANTI-CLAMP SENSOR (EXAMPLE: IN.15.737)



**TOP SENSOR
IN.15.737**

Anti-clamp sensor when opening

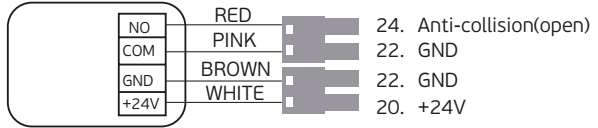

Anti-clamp sensor when closing

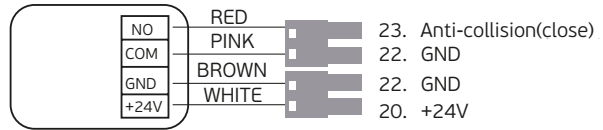

5.8. ANTI-CLAMP SENSOR (EXAMPLE: IN.15.730)



**DOUBLE ACTION SENSOR
IN.15.730**

Anti-clamp sensor when opening

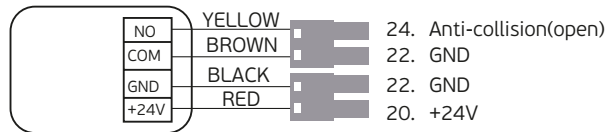

Anti-clamp sensor when closing

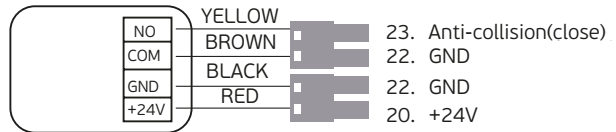

6.1. OPERATION OF THE REMOTE CONTROL



A. ALWAYS OPEN

B. AUTOMATIC

C. OPEN/CLOSE ONE TIME

D. FULL LOCK/EXIT ONLY

ADD THE REMOTE CONTROL

press the learning button on the controller until the indicator turns from green to red. Then release the learning button and press the A button on the remote control, the indicator will turn from red to green alternately 3 times meaning the learning is successful.

DELETE THE REMOTE CONTROL

press and hold the learning button, after 6 seconds, the indicator will turn from green to red and then green again. (attention: please hold the learning button when you have to delete the remote control memory)

WIRELESS PUSH BUTTON

to add or delete the wireless push button is the same as the remote control. Please check if the DIP switch is the same as the image shown during the setting process

**NOTES:**

1. The receiver has been built-in.
2. EXIT ONLY FUNCTION
connect the outside sensor/button to the terminal OPEN-B
connect the inside sensor/button to the terminal OPEN-A
press the FULL LOCK button on the remote control
3. When in the double open mode, the synchronous cable must be connected (see manual). When the power is ON ensure the settings on both controllers are the same. If the speed is different during the operation, please slightly adjust the open/close speed, the open/close braking speed and the opening time.
4. When in the double open mode, the remote control must learn both controllers in order to control the two doors at the same time.
5. In the double open mode, the accessories should be connect to both controllers (parallel connection)

CODE	SETTING RANGE	DEFAULT	DESCRIPTION
01	30-99	60	opening speed (velocity open)
02	30-99	50	closing speed (velocity close)
03	1-30	10	braking opening speed
04	1-30	10	braking closing speed
05	10-50	30	braking opening angle
06	10-50	30	braking closing angle
07	0-60	2	hold-open time (0-60s)
08	2...8	3	starting delay time (1-4s, 1=0,5s, when lock function is working)
09	0,1,2...8	2	locking delay time (0-4s, 1=0,5s)
10	0,1	0	locking type (0: lock by remote. 1: auto lock when closed)
11	0,1	1	locking type (0: working. 1 : not working)
12	1,2,3,4,5	2	obstacle detection optimized for exterior (wind loads)
13	1,2,3,4,5	2	holding force-closed
14	1,2,3,4,5	3	anti-collision force
15	5-30	15	auto-learning speed
16	0,1,2...10	4	working interval between master and slave door (0-1s, 1=0,1s) on master door, the setting is working when closing; on slave door, the setting is working when opening

8. LED DISPLAY FEEDBACK

8.1. SINGLE OPENING

LED DISPLAY	DETAILS
Dr11	No problem
Dr12 or Dr13	Terminal 11 and 13 are not connected. (They should be connected when single opening)
Er01	Over current prote on for controller
Er02	Motor has problem

8.2. DOUBLE OPENING

LED DISPLAY	DETAILS
Dr12	Master door
Dr13	Slave door
Er01	Over current prote on for controller
Er02	Motor has problem
Er03	Synchronous wired problem
Er04	Master door and slave door problem

SYMPTOMS	CAUSES	ITEMS CHECKED	REMEDY
door opens/closes unsmoothly	opening/closing speed is set too slow	check the opening/closing speed	speed up the opening/closing speed
	learning speed is too fast	check the learning speed	slow down the learning speed
	too much resistance	check whether there is something on the door's working way	clear the obstacle away
hits the door frame suddenly when closing	buffer speed when opening/closing is too fast		slow down the buffer speed when opening/closing
	stopper is loosen		fix the stopper
door does not work	no power	check the power switch connection terminal from motor to controller	connect the power
	learning speed is too slow		speed up the learning speed
	door is locked	check whether the door is locked	unlock the door
	obstacle in the pull bar guide	check the pull bar guide	remove the obstacle
	resistance force is too strong		power off, push the door leaf. make sure the door works smoothly
door can not open	there is an obstacle in the path		remove the obstacle
	learning speed is too slow		adjust the learning speed (faster)

